

HUD Installation for the C6 Corvette (Revision 2)

Preface

Car Details: 2007, A6, Z51

Installing the HUD should be the same for all 2005 and up model Corvettes (1LT and 2LT). If you are trying to install HUD on your 3LT or 4LT car, you can stop reading here.

After hearing about how other people have successfully installed the HUD into their cars, I became interested in doing it myself. Total out of pocket cost for all the parts I needed was \$700, and all were purchased from the C6 Parts for Sale/Trade board of the forum.

I tried to take pictures along the way but slacked off a bit towards the end. I've used other pictures that I found on the forum if I thought they would be helpful in making a point. If anyone is the rightful owner of these pictures and would like them removed from this guide, please let me know.

All you need is:

1. HUD Projector (and mounting hardware)
2. Control Switch Assembly
3. Custom Harness (with T tap connectors to make your life easier)
4. Plastic HUD surround (bezel)

I've heard many things about the HUD install such as "you don't need to completely remove the dash" or "you do not have to remove the steering wheel." Forget anything you've might have read and pay attention to my advice below.

Things you should know before you attempt this install:

- You will need to remove the complete dash assembly. I honestly do not believe you can avoid this. Removal of all the fastening hardware can be done by yourself but I highly recommend having an extra pair of hands to help you remove the dash assembly from the car.

Revision 2 Update: You can avoid removing the dash out of the car but you will still need to remove all of the fasteners. Once the dash is loose if you lift it up high enough with the HVAC duct you should be able to shoehorn the HUD projector in place. Also, if you do this method you can most likely complete the HUD installation by yourself.

- You will need to remove the steering wheel. I recommend removing the steering wheel. While you can get the dash assembly out without removing the wheel, you will need to break a portion of the dash to do this. Ask me how I know.

Revision 2 Update: You can avoid removing the steering wheel if you decide to leave the dash in the car. With the column all the way down you should have enough room to get the HUD projector in place while lifting the dash completely. The wheel only needs to come off if you plan on removing the dash from the car. If you leave the wheel in, wrap it with some sort of protection (painter's tape, towel, or whatever) so you can avoid getting scratches and nicks in the leather.)

- You will need to remove the center console and radio surround. No worries here; this is easy and well documented.

Tools you will need:

- 7 mm (I used a nut driver mostly, used a deep socket a few times, and also a few times with an extension.)
- 10 mm (I used a nut driver mostly, used a regular socket a few times)
- Phillips screwdriver (#2 worked for me)
- 15 mm socket (for steering wheel removal)
- T15 Torx bit and driver
- Worklamp or flashlight (comes in handy looking under the dash)
- Metal Punch (#3 or 4) (to remove the airbag; even a piece of metal coat hanger would work)
- Steering wheel puller (GM # J1859-A for the puller, J36541-A for the puller legs)

Tools/items that may help:

- Multimeter or continuity tester (for troubleshooting)
- Pliers (if you have no hand strength for the t-taps)
- Electrical tape (for securing the harness wires after tapping into them)
- Razor Blade or Sharp Knife (removing electrical wrap)

Safety Notice: I recommend removing the positive battery cable and the airbag fuse (SIR). It's not likely they would accidentally deploy but this guarantees they will not. Also, there are many sharp edges, mostly plastic under the dash. Exercise caution or you will have many tiny cuts on your hands.

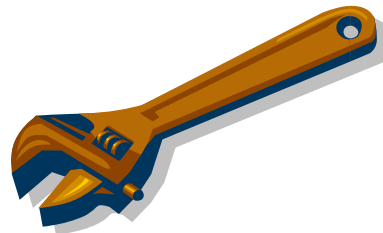

Another helpful tip is to keep the windows down, or the doors open before removing the battery cable. Otherwise you will have to have your key handy to get back into your car

Step 1: Center Console/Radio Surround Removal

The pictures I've taken will work for 2005 – 2007 models. 2008 and up models will have a slight difference which I will attempt to cover.

The first thing to do is remove the center console lid. It is held on by four T15 torx screws. You can then remove the small plastic covers for the rear hold down nuts. The picture below shows the console lid and nuts already removed.

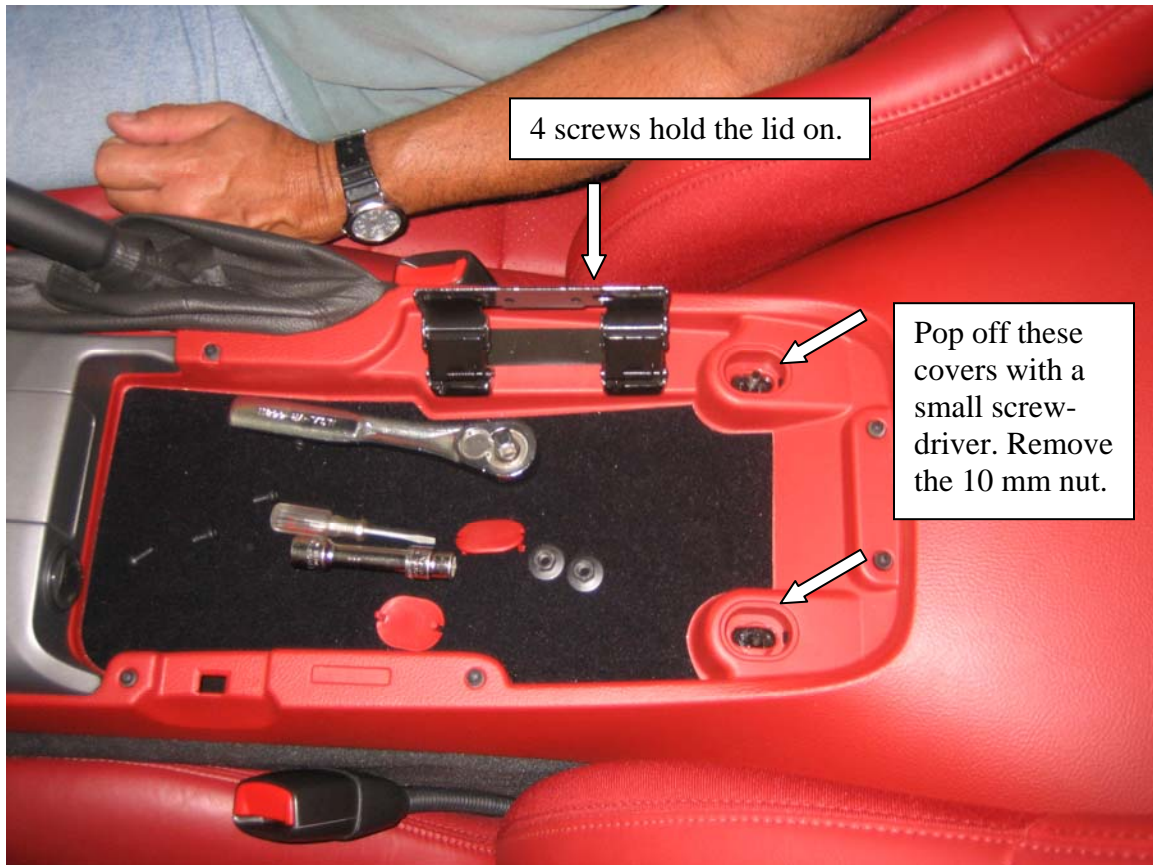

Turning attention towards the front of the console, the shift knob will need to be removed. Twist the plastic ring at the top of the leather boot clockwise maybe 35 degrees or so and then pull up on the shift knob. You will need to use some force here but don't worry, you shouldn't break anything. Note that I had the car in neutral with the E brake pulled but I do not believe it is necessary.

Note if you have a manual transmission car you can find instructions to remove the knob at <http://www.nakidparts.com> under "Instructions."



To remove the emergency brake handle, pull down the leather boot and remove the Phillips head screw. Pull up on the shift handle to remove it. This took much more effort than I thought it would.



Next, remove the two bolts on the right side of the console.

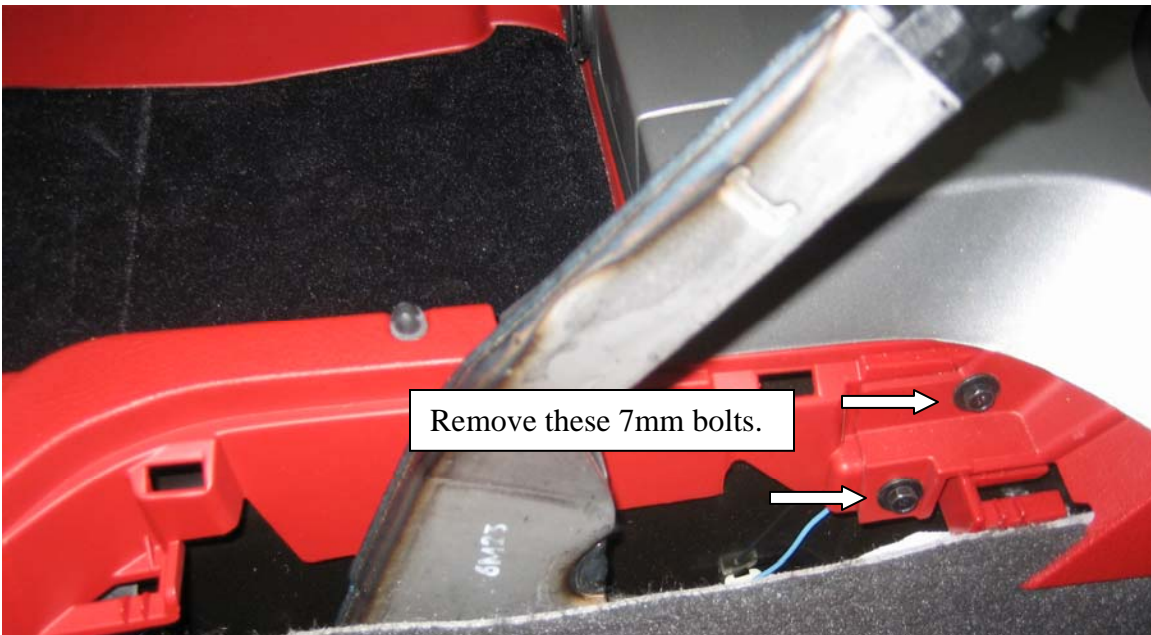

Towards the center of the console there is another bolt to remove. To access it, remove the Ride Select Cover by pulling it upwards. I was able to do it by hand but you may use a screwdriver or knife to help.

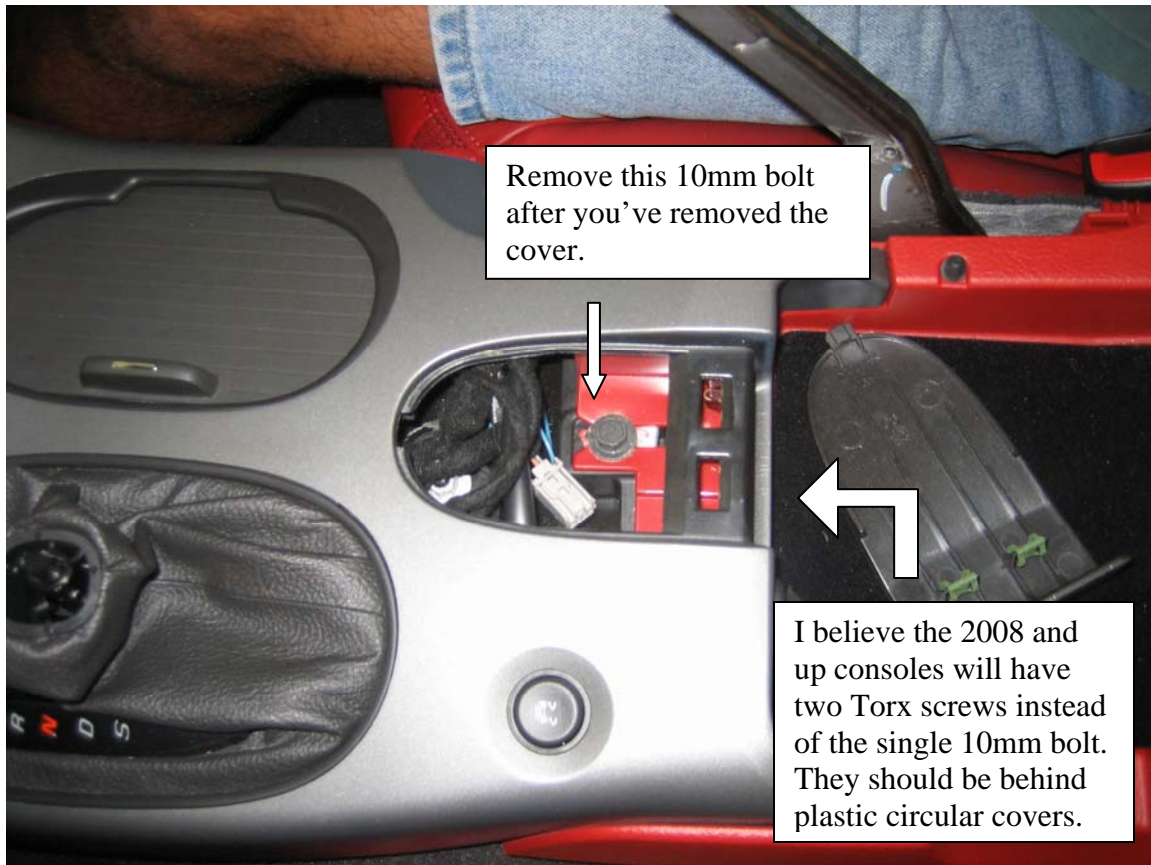

Now you are ready to begin prying the console up, starting from the rear most section. The rest of the console and radio surround will be held in with clips. Once again, don't be afraid to use some force. As you remove the console, you will need to unplug the electrical connectors going to the

- console mounted cigarette lighter (power plug)
- some other connector (see picture)
- traction control button
- emergency flasher button
- ashtray cigarette lighter
- F55 switch (if equipped)
- Heated seat buttons (if equipped)



Most of the connectors are fairly easy to remove. There's usually some kind of lock or place to depress to release the connector. Having big hands makes this job a bit more difficult. Employing the use of a short flat head screwdriver helped for me. I would

recommend labeling all of the connector by some means, preferably with something nice and visible. There is little to no change of getting the connectors confused with one another but you could miss reconnecting one of them if you are not careful. You'll never know it until something doesn't work. The last step is to remove the A/C control and radio. They are held in by 7mm bolts that are easily visible. Disconnect the electrical connectors in the back and you are all set. Note that the A/C controls come out first.

And look on the bright side, if you accidently break something you can replace it with something nice from DownSouthVettes.



Step 2: Instrument Panel Removal

Note: You can remove the steering wheel first (Step 3) if you'd like.

The first step is going to be removing the upper gauge surround panel. The entire assembly is just snapped into place. You just need to gain a little leverage to pull the piece off. Using something skinny and flat (butter knife shown below), pry the bottom of the panel outward, at least until you can get a good grip with your fingers. Support with your hands as much as possible and pull firmly to release the clips.



The electrical connectors that need to be removed on this panel is the dinner switch, engine start/stop button, the DIC control pod assembly (buttons), and some long cylinder thing that looks like a temperature measuring device with a small fan in it.

In the picture to the right you will see the little slits on the left side of the start button. This is where the temperature device with the fan is. There is no special trick to removing it off the panel. Just grab the whole thing and pull it off. It is that simple.



Here is a picture of the device I am referring to.



Instead of removing the DIC control pod connector, you can remove the three screws holding it in place and remove the connector later.

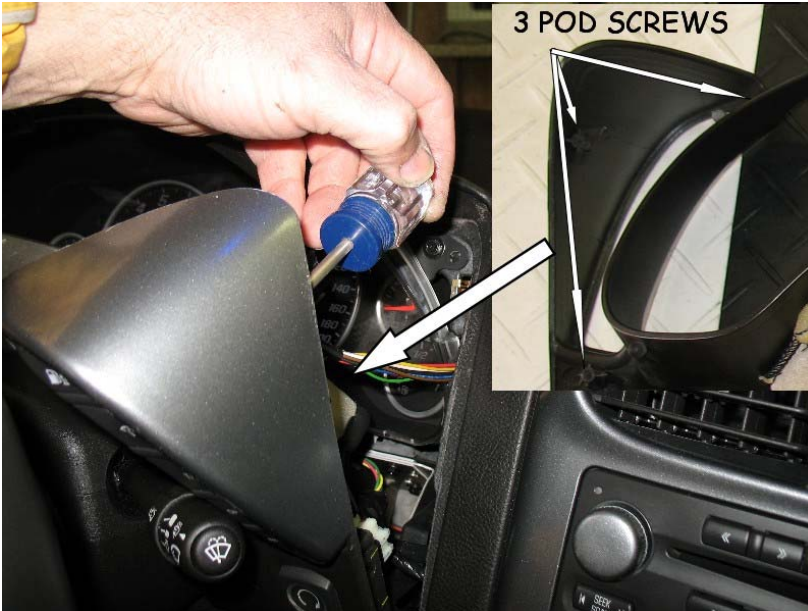

This picture shows all of the clip locations. This should give you some idea of where you will need to provide more force.



Once the upper section is removed, you can remove the knee bolster panel and its support bracket. There are two T15 Torx screws and the bottom of the panel and the top is held with clips. You need only remove the electrical connectors for the fuel door release and hatch release buttons. If you have On Star, you may also have another connector near the console side of this panel.

2-30 Instrument Panel and Console Trim

Driver Knee Bolster Panel Replacement

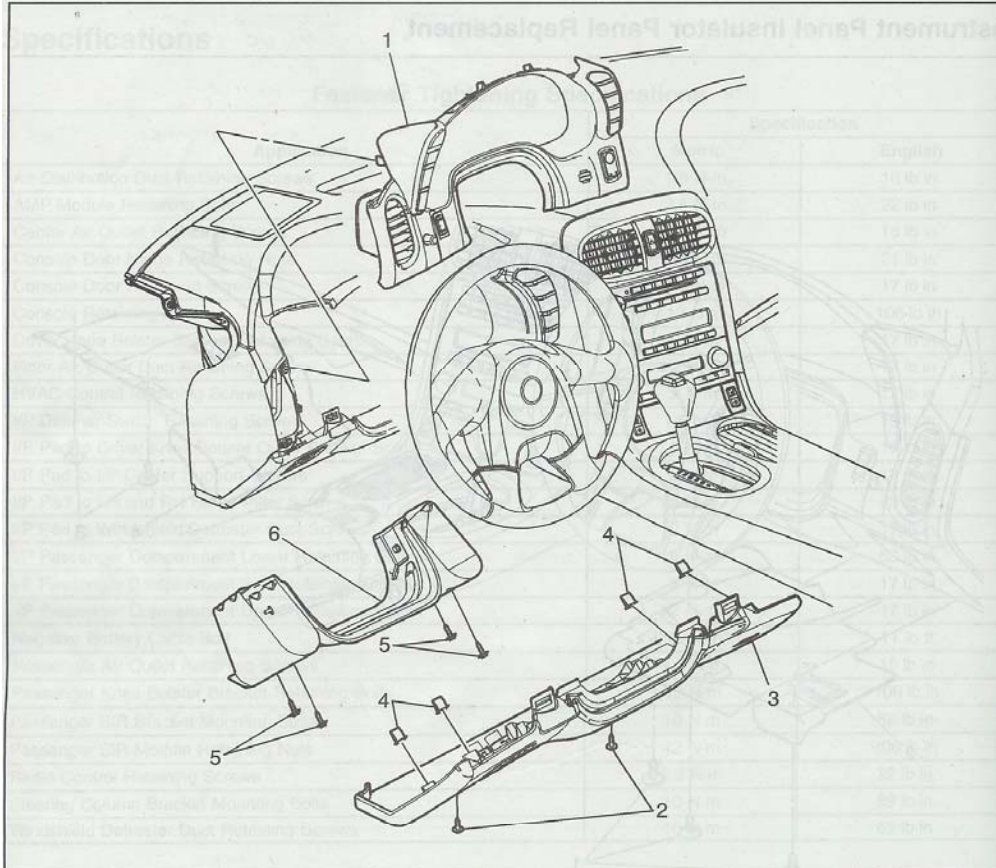

1479502

Driver Knee Bolster Panel Replacement

Callout	Component Name
1	Instrument Panel Cluster Trim Plate Refer to <i>Instrument Cluster Trim Panel Replacement</i> on page 2-33.
2	Instrument Panel Knee Bolster Screws (Qty: 2) Notice: Refer to <i>Fastener Notice</i> on page 0-10. Tighten 2 N-m (18 lb in)
3	Instrument Panel Knee Bolster Panel Tip: The electrical connector must be disconnected from bracket/panel.
4	Instrument Panel Knee Bolster Clips (Qty: 4)
5	Instrument Panel Knee Bolster Bracket Bolts (Qty: 4) Tighten 2 N-m (18 lb in)
6	Instrument Panel Knee Bolster Bracket



This picture shows one of the T15 screws. (Callout 2)

This picture shows the metallic knee bolster bracket. There are four 7mm bolts to remove.

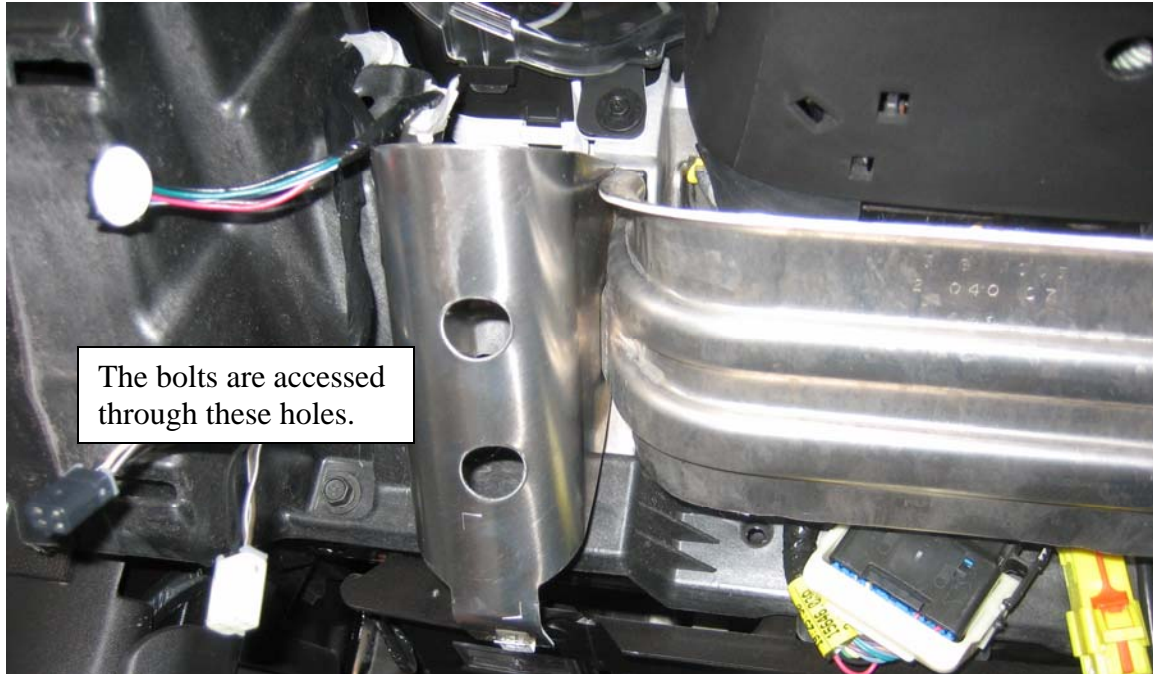

The last step here would be to remove the gauge cluster itself. There are four 7mm bolts securing the gauge cluster. Remove them and you will be able to pull the cluster out. There is plenty of length for the wires on the back so you can remove the cluster and have easy access to remove the connectors.

After you have the gauge cluster out, I would recommend taking a few pictures so you can see how the wiring and everything is sorted.

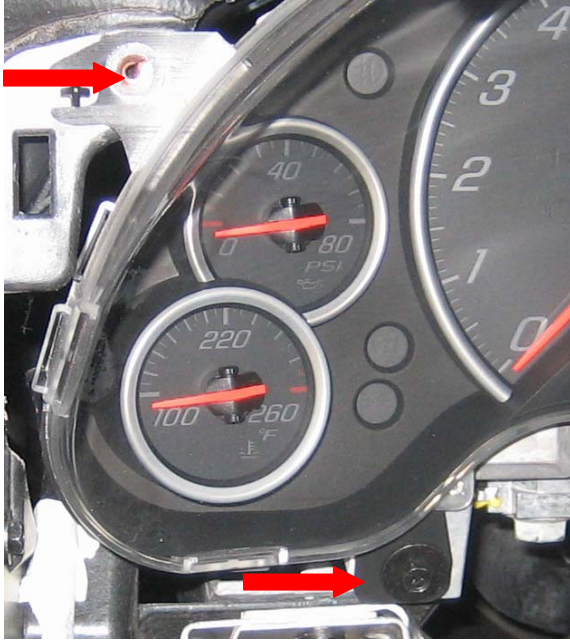

Step 3: Steering Wheel Removal

[Revision 2 Update](#): You can avoid having to remove the steering wheel. See the Preface section for details.

Reminder: Make sure the airbag fuse (SIR) is pulled before attempting to remove the steering wheel.

Let me just say that for my HUD installation, I did not remove the steering wheel. I ended up breaking a piece of the dash trying to take it out because of this. For me, it's not a big deal. I glued the piece back together so that it won't ever come apart, and more importantly, won't create any rattles down the road. It's also on a part completely hidden by other panels.

For the purposes of this guide, though, I suggest removing the steering wheel as it doesn't appear to be that difficult. You will just need to rent, borrow, or buy the steering wheel puller.



First off, you will need to remove the airbag module. To do this, insert a blunt ended tool (metal punch, section of a metal hanger, etc) into the circular openings (one at 3 o'clock, the other at 9 o'clock) and push. It may be helpful if the steering wheel is positioned to where one of the holes is on top. There is a spring fastener inside which should release. Repeat for the other side of the steering wheel and the airbag and cover should come right out.

You will then need a 15 mm socket to remove the hub nut. After that, mark the steering wheel and the hub (shaft) so you will be to realign the wheel when reinstalling. Use a steering wheel puller to remove the steering wheel and remove electrical connectors where necessary.

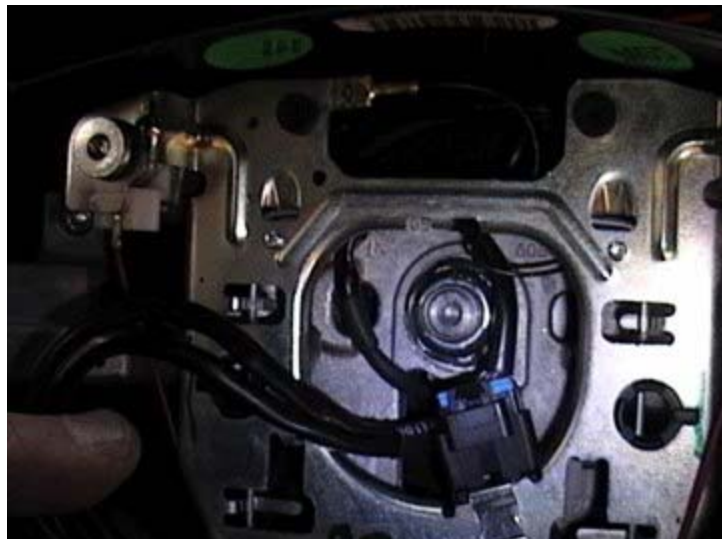

I'll show repair manual scans to give you a better idea of how it fits together and for the proper torque specifications if you care to use them.

13-126 Supplemental Inflatable Restraints

Inflatable Restraint Steering Wheel Module Replacement

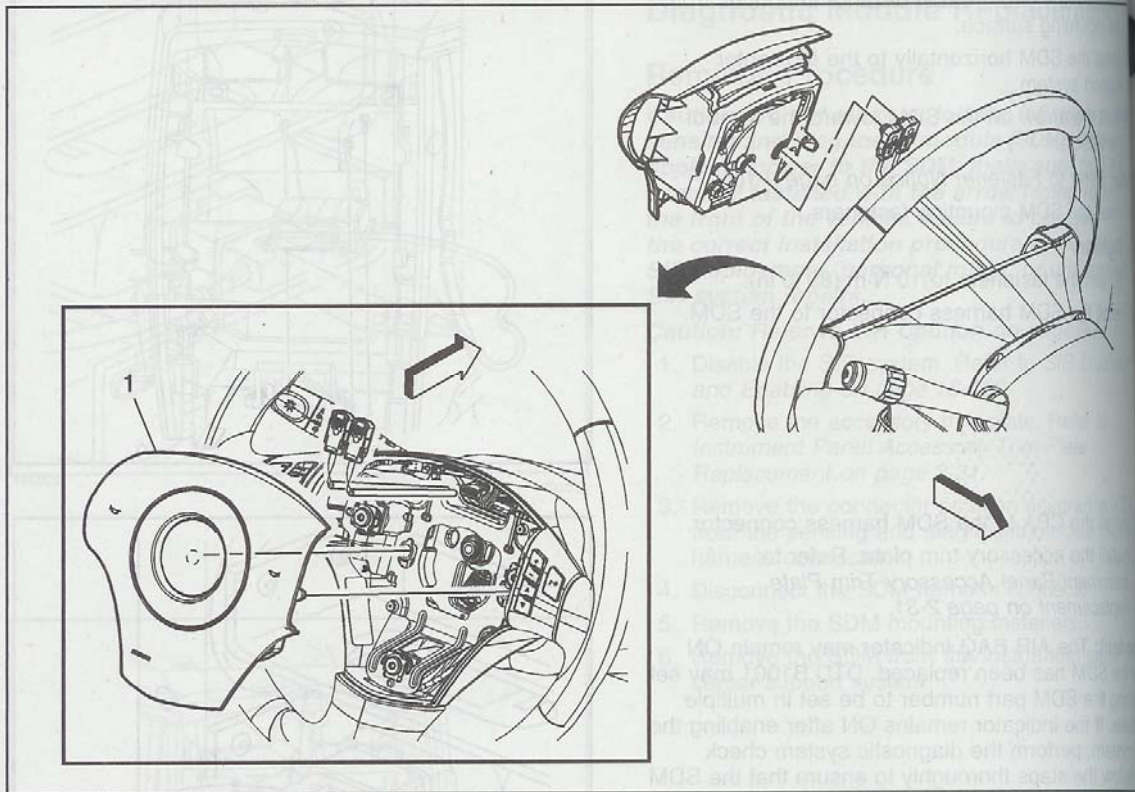

Inflatable Restraint Steering Wheel Module Replacement

Callout	Component Name
<p>Caution: Refer to <i>SIR Inflator Module Handling and Storage Caution</i> on page 0-7.</p>	
<p>Caution: Refer to <i>SIR Caution</i> on page 0-7.</p>	
<p>Preliminary Procedures</p>	
<p>1. Disable the supplemental inflatable restraint (SIR) system. Refer to <i>SIR Disabling and Enabling</i> on page 13-120.</p>	
<p>2. On the sides of the steering wheel are 2 circular openings, place the wheel so that one opening is on top.</p>	
<p>3. Using a blunt-ended tool, push the spring fastener inward through the access hole. Repeat the step for the other opening.</p>	
<p>1</p>	<p>Steering Wheel Inflatable Restraint Module</p> <p>Tip:</p> <ol style="list-style-type: none"> 1. Release the connector position assurance (CPA) retainer. 2. Disconnect the electrical connectors. 3. Fully deploy the module before disposal. If the module was replaced under warranty, fully deploy and dispose of the module after the required retention period. Refer to <i>Inflator Module Handling and Scrapping</i> on page 13-140.

Steering Wheel Replacement

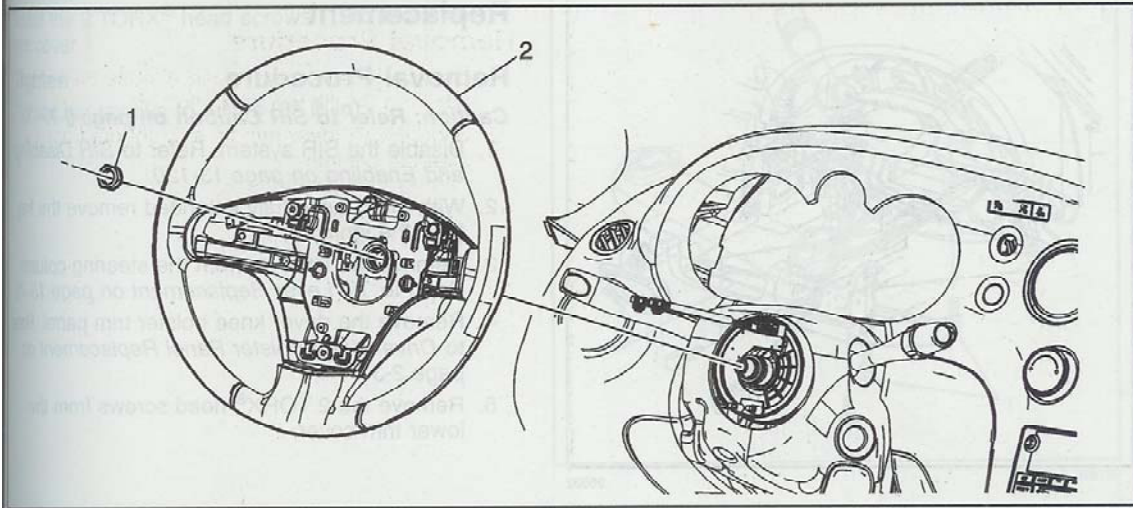

1581905

Steering Wheel Replacement

Callout	Component Name
<p><i>Notice:</i> Refer to <i>Fastener Notice</i> on page 0-10.</p>	
<p>Fastener Tightening Specifications: Refer to <i>Fastener Tightening Specifications</i> on page 15-26.</p>	
<p>Preliminary Procedure</p>	
<p>Remove the inflatable restraint steering wheel module. Refer to <i>Inflatable Restraint Steering Wheel Module Replacement</i> on page 13-126.</p>	
<p>1</p>	<p>Steering Wheel Nut Tighten 37 N·m (27 lb ft)</p>
<p>2</p>	<p>Steering Wheel Assembly Tip:</p> <ol style="list-style-type: none"> 1. Disconnect the electrical connector. 2. Remove the steering wheel using <i>J 1859-A</i> Steering Wheel Puller with <i>J 36541-A</i> Steering Wheel Puller Legs. 3. Make an alignment mark to note the relationship between the steering wheel and the steering shaft. The marks will be needed to align the wheel during installation.

Hopefully the information I've provided assists with removing the wheel.

Step 4: Dash Assembly Removal

Now it's time for the last part of the disassembly process. I will try and point out every nut and bolt that you need to remove.

[Revision 2 Update: You can avoid having to remove the dash. See the Preface section for details.](#)

I'm sure we're all familiar with the exploded dash view.

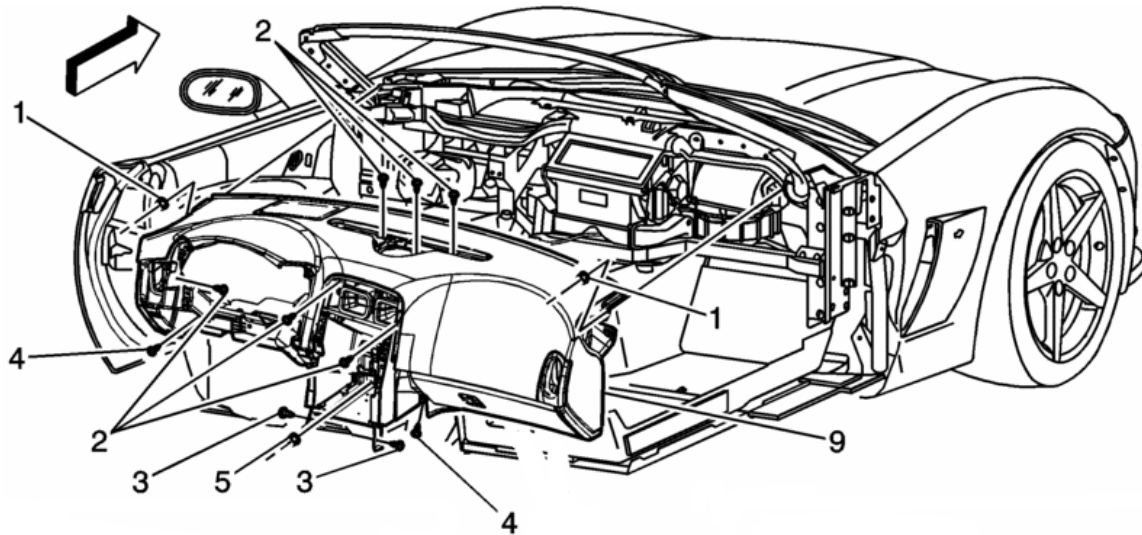

Let me say that it is accurate, but it may not be easy to find them all. Removing all of the fasteners can be easily accomplished by yourself. For actually removing the dash panel, you will need a hand.

Before we can tackle all of these fasteners you will need to remove some of the panel trim on both the driver and passenger sides. (A pillar trim and body hinge trim)

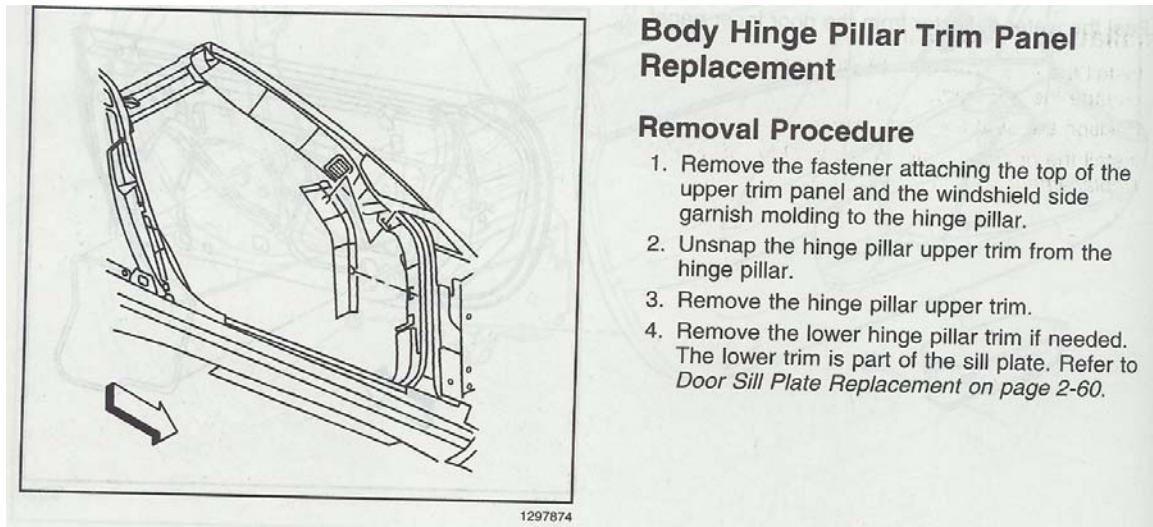

Note, it may be quite difficult to remove these trim pieces. I had to use something very thin and flat to pry it up enough to grasp it and pull it loose.

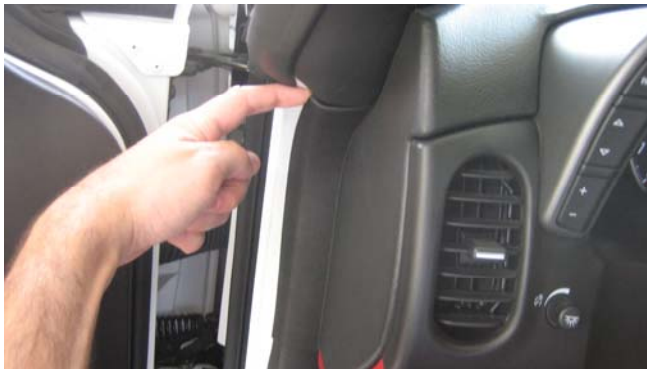

It just snaps in place. After you removed this piece remove the A pillar trim panel. Like everything else, it just snaps in place so pull on it till it comes off. If you have On Star there may be a connector behind the driver's side A pillar. I'm not sure but I remember hearing something about it.

This is the reverse side of the driver's A pillar trim. You can see the location of the clips.



For removing the dash, you can pretty much start anywhere, but I'll go ahead and start with the glove box first.

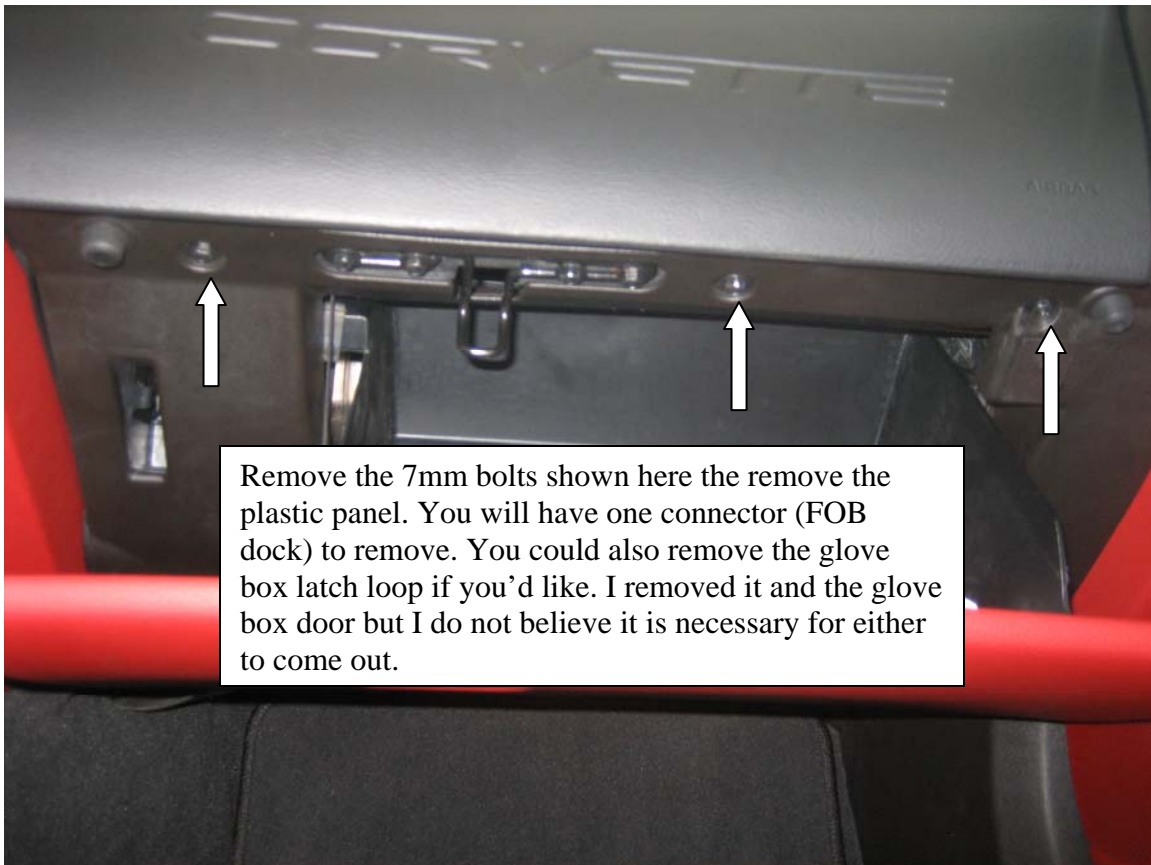
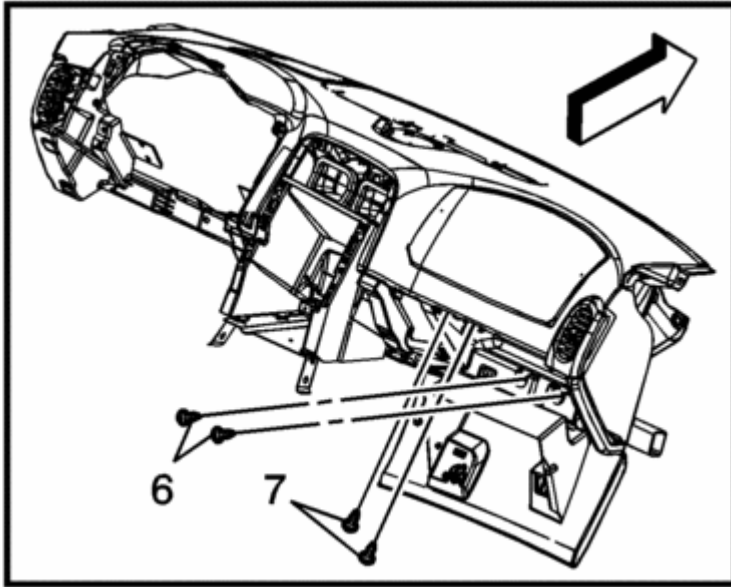

Remove the 7mm bolts shown here the remove the plastic panel. You will have one connector (FOB dock) to remove. You could also remove the glove box latch loop if you'd like. I removed it and the glove box door but I do not believe it is necessary for either to come out.

At this point, I would remove the passenger side A/C vent. Just clipped in so get a grip on it and pull. Continuing with the passenger side of the dash, remove the three 10mm bolts holding the dash into the passenger side airbag module. This did take me a little while to locate. Two are located vertically while the middle one points towards the driver's side of the car.

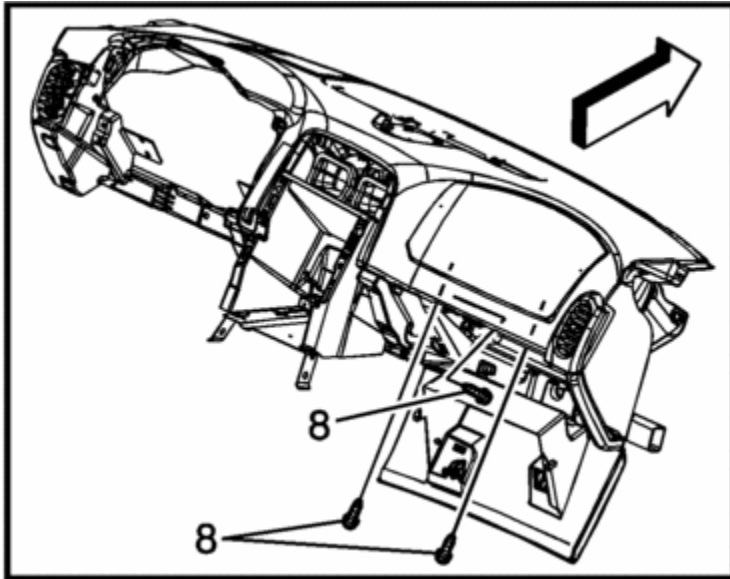

The picture you see below is looking up from the floorboard at the under side of the passenger side dash. Here, the plastic cover and the glove box door have already been removed.

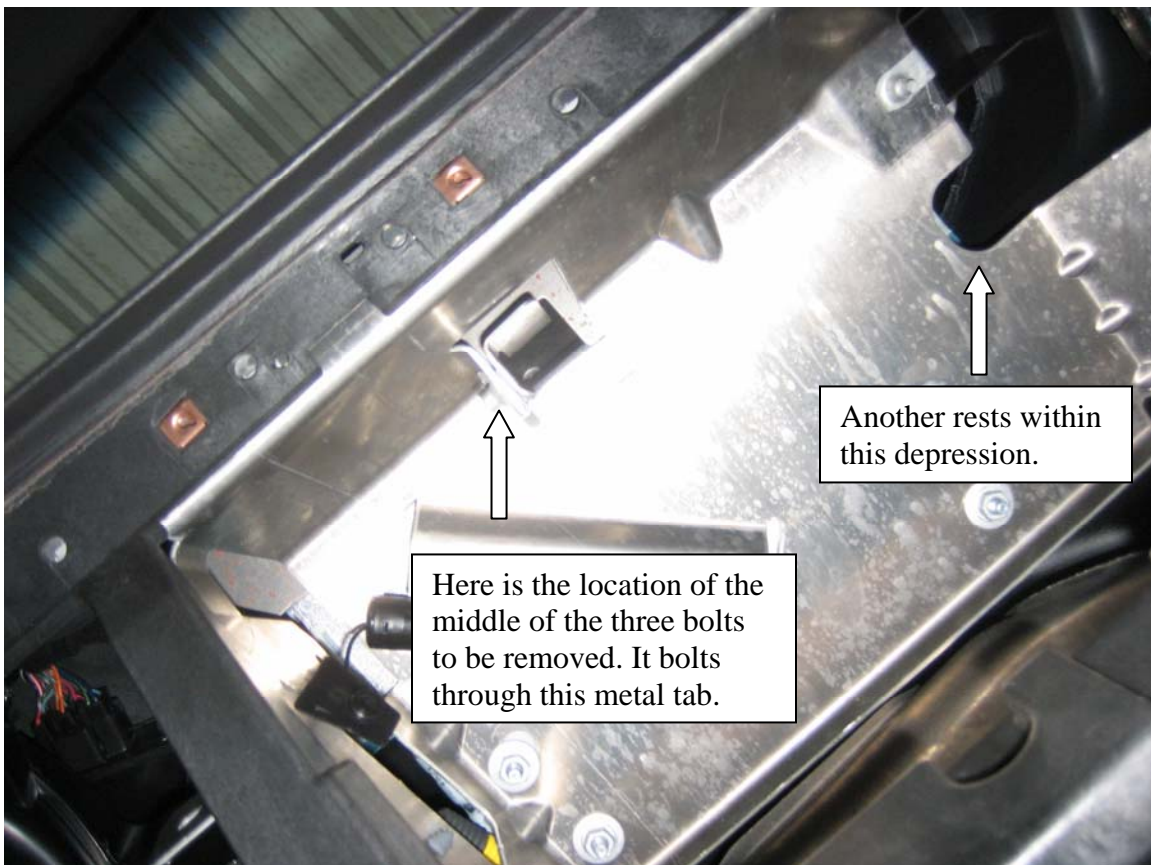

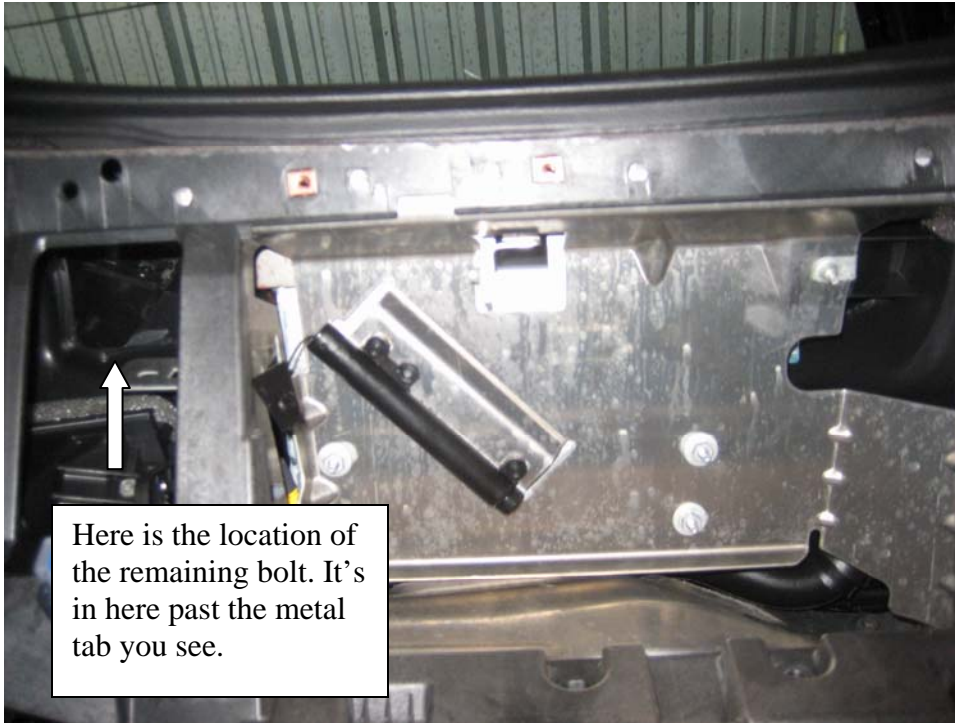

Here is the location of the remaining bolt. It's in here past the metal tab you see.

And better pictures of the final locations.



By this point, you should already have the A pillar trim removed. Locate the dash retention nut (7mm) on the passenger side and remove it. Before you get to it, you will have to take the plastic ring off around the stud. I needed a deep socket for this. Referencing the main exploded diagram, this takes care of #1 on the passenger side.

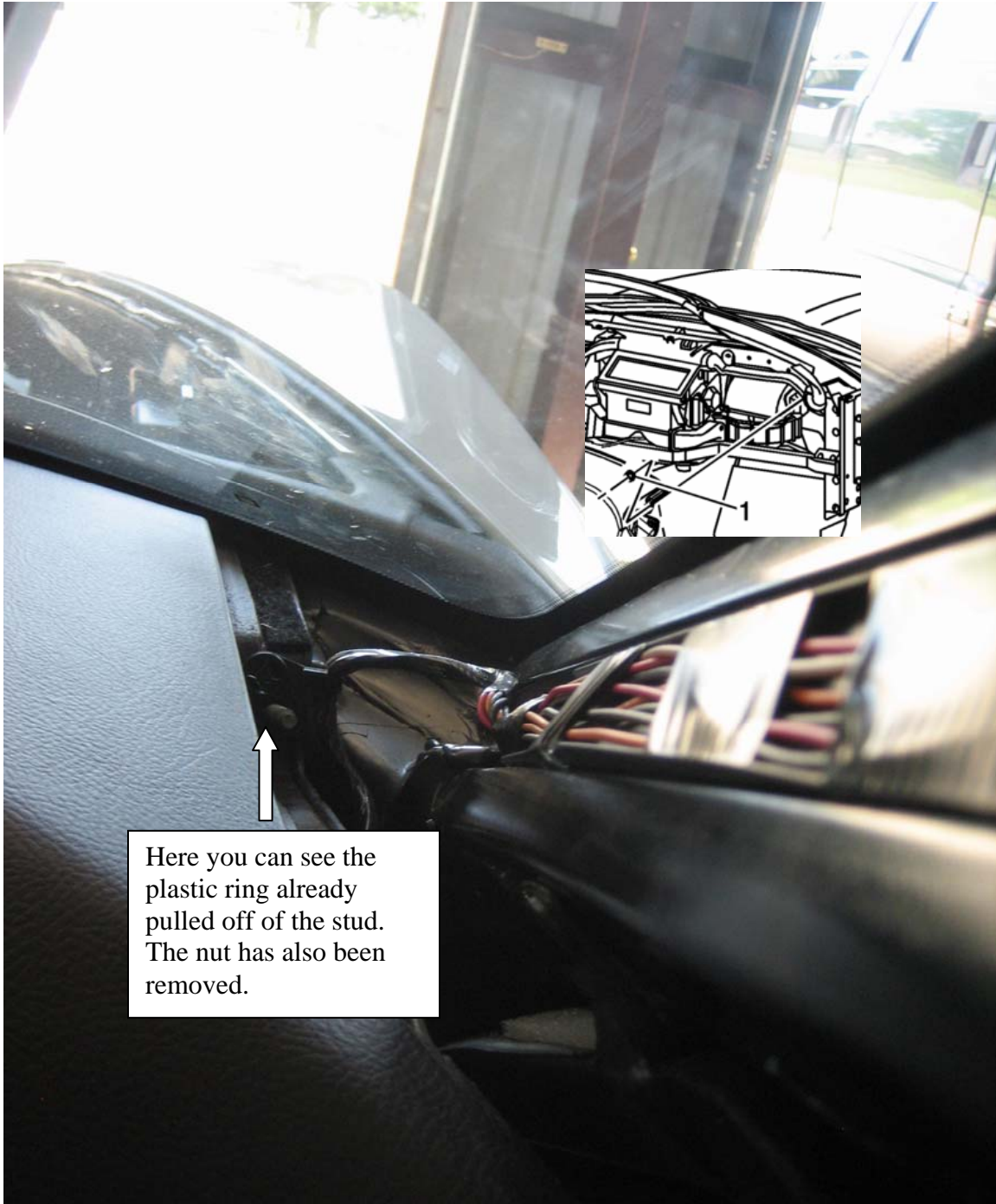

Here you can see the plastic ring already pulled off of the stud. The nut has also been removed.

Okay, let's go back under the passenger side dash to get the final two bolts (for this side). The picture you see here is from the passenger seat. The metal bracket extended down in the bottom left comes off of the console/radio surround pod. (There's another like it on the driver's side).

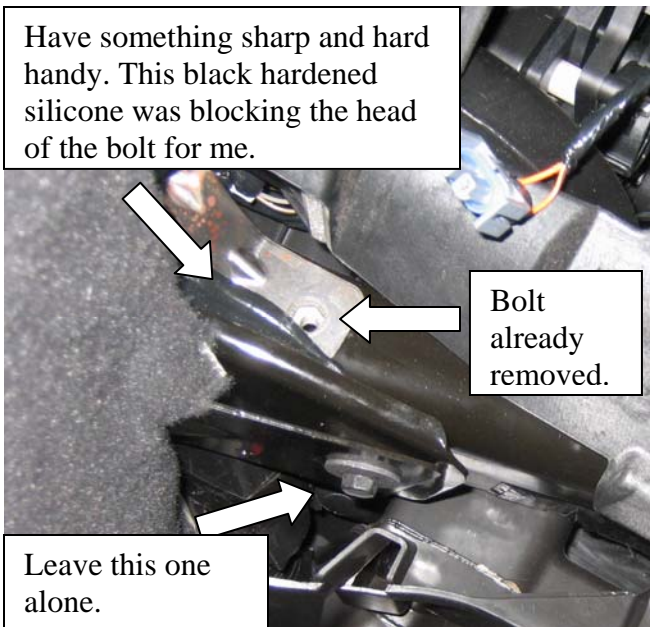
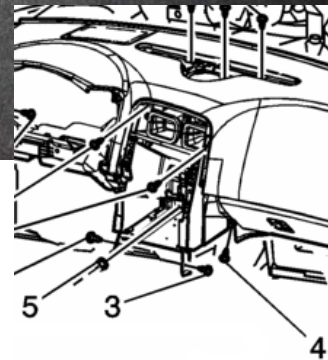
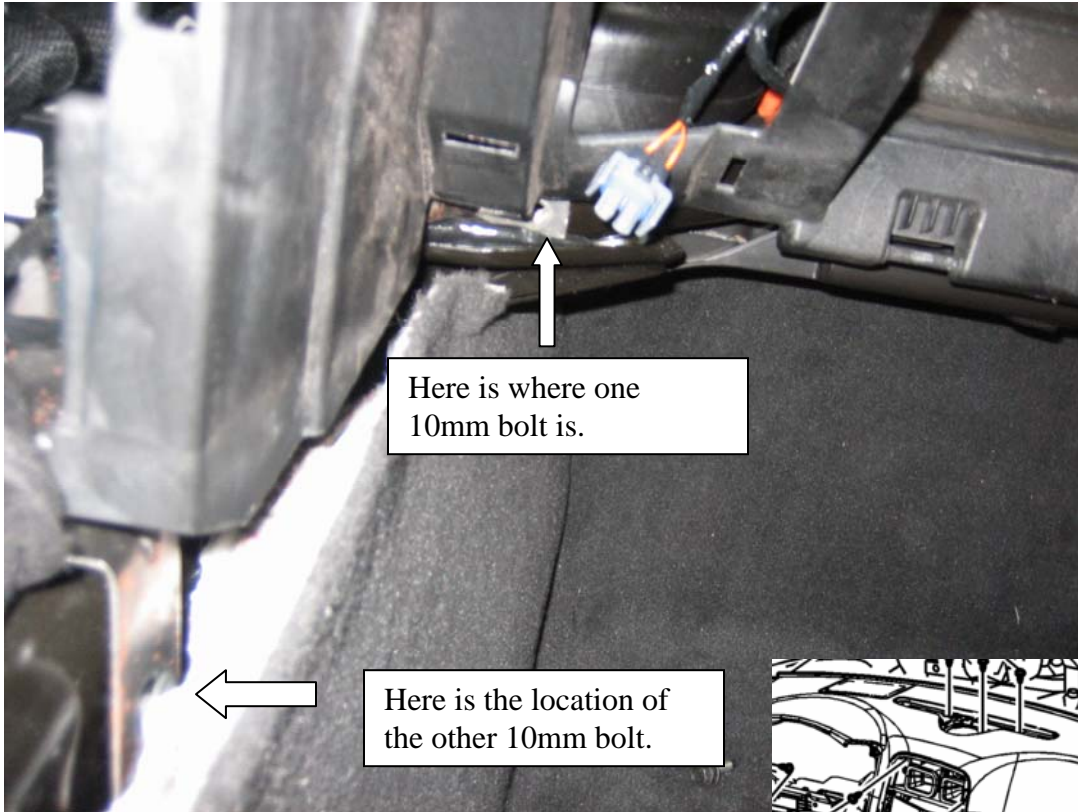

Here you can see a better picture of the location of the bolt just above the cradle.

This takes care of #3 and #4 on the passenger side.

Moving back to the top of the dash, let's remove the three 7mm bolts near the center speaker. First things first, remove the center speaker grille. It's held in with clips so pry up the end with a screw driver and then work the rest out by hand. This piece seems fragile but I had to pull on it quite hard to get it out and it didn't break. An alternative to prying and possibly marring the plastic, is to stick your hand into the void created by the missing gauge cluster. You should be able to touch the bottom of the left side of center grille and push upwards, releasing the clip. This is what I did. The following picture is with the grille already removed. At this point I would also recommend removing the center speaker and the ambient light sensor connector (obstructing your view of the third bolt).

This will take care of #2 on top of the dash.

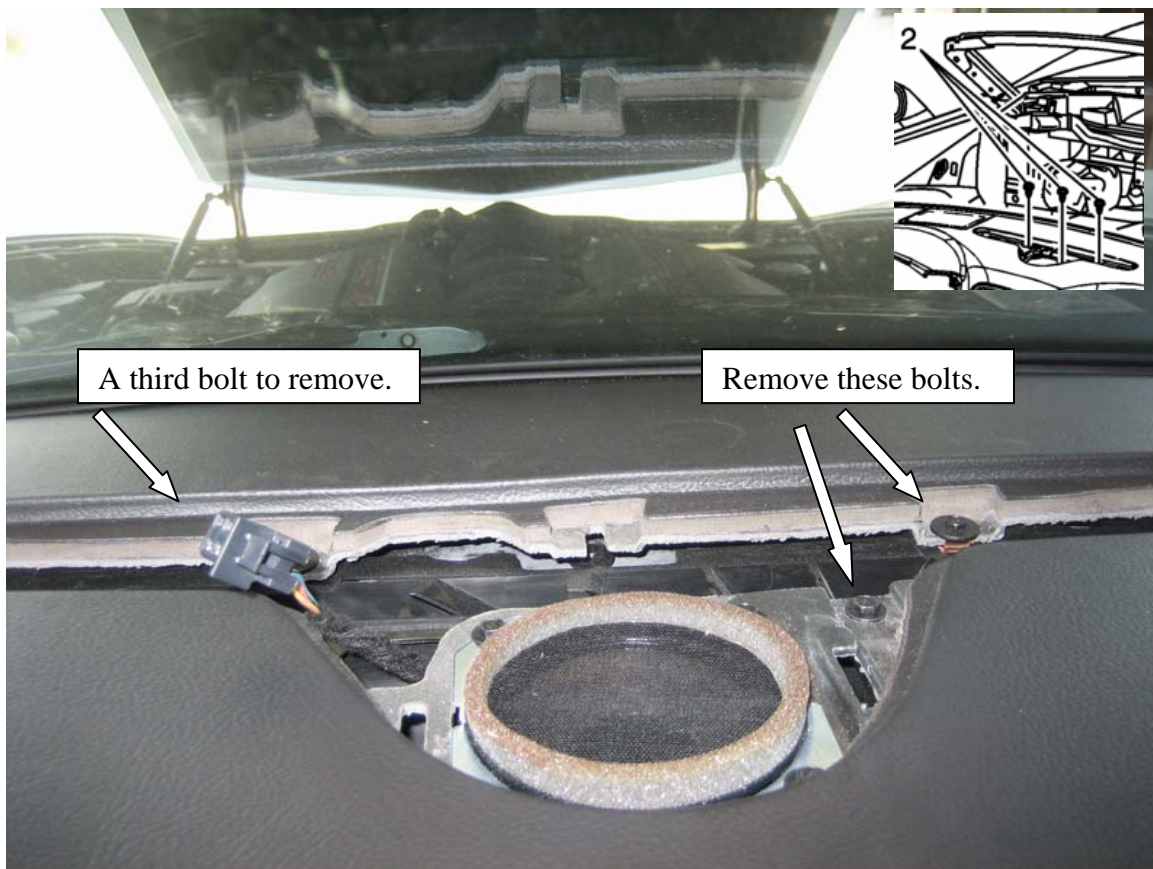

On the front face of the radio surround there are two 7mm bolts to remove and one nut. While you are down here, remove the driver's side #3.

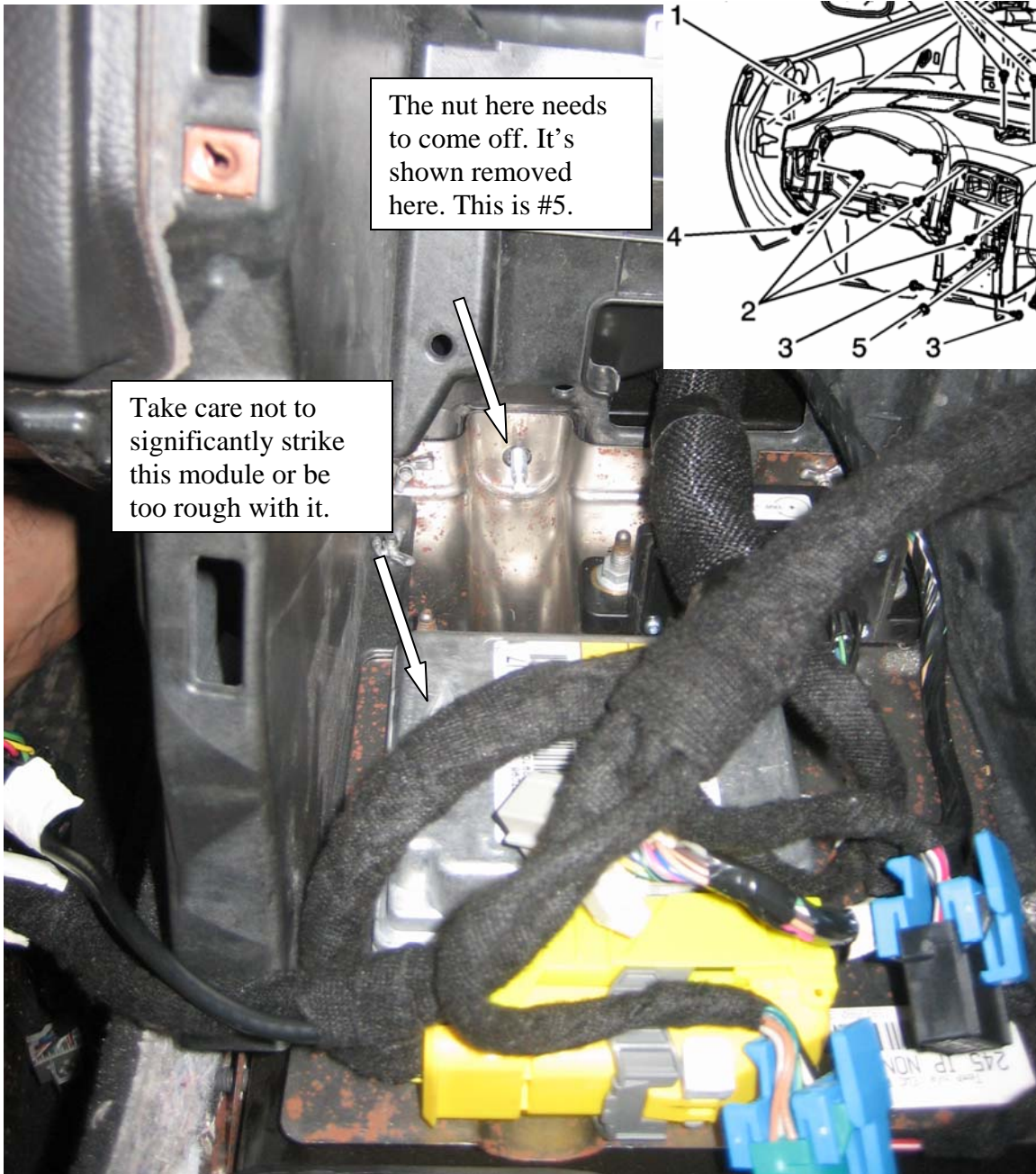

There are two bolts to the top of the radio surround that need to be removed, one at the right and one at the left. The one towards the driver's side is pictured below.



The bolt here needs to come out. It's shown removed here. This is #2.

The next bolts to remove are just to the left of the steering column.



The bolt here needs to come out. It's the last of #2.

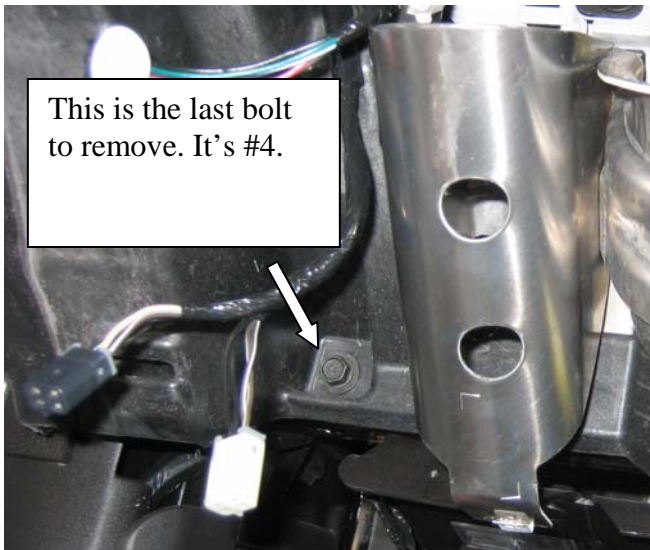

This is the last bolt to remove. It's #4.

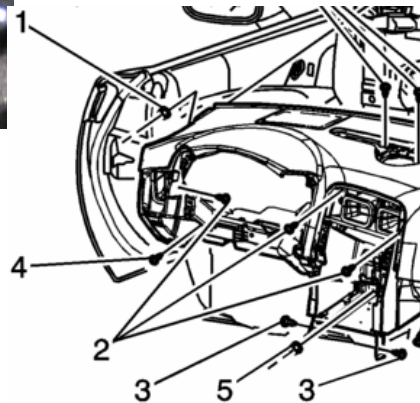

This should be the last bolt you have to remove.

The last of the fasteners to remove is the nut down behind the driver's side A pillar.



Rejoice! You are done removing all of the fasteners.

Step 5: Electrical Harness/Connector Notes

So you are done removing all of the fasteners but you are not quite ready to take the dash out yet. There are some electrical connectors you still need to remove before the dash will come out nicely. Remember this picture? All of those wires and harnesses need to be disconnected so the dash will come out. They are easy to remove; just take your time.



These connectors do not need to be unplugged but they will need to be removed from the plastic crossbrace they are on. The plugs are not mounted to the brace directly. They slide over plastic clips which are secured to the brace with push pins. Just slide the plugs off of the plastic clips.



You are now ready to remove the dash.

[Revision 2 Update: You can avoid having to remove the dash. See the Preface section for details.](#)

One thing I would like to point out is that the service manual also mentions that you should remove the automatic transmission control. Now, I didn't do this on my A6 and the bottom of the dash under the radio and A/C section would get caught on the lip of the shifter control plate. The plastic did have enough flex to get around the plate so I do not believe it is a necessary step. If you would feel better removing it and not taking any chances, let me know. I can scan in the section of the manual concerned with removing the shifter assembly.

Now you and a friend should each take a side of the dash assembly and slowly move it up and out, away from the firewall.

Hopefully it comes out without too much of an ordeal.

Instrument Panel Assembly Replacement

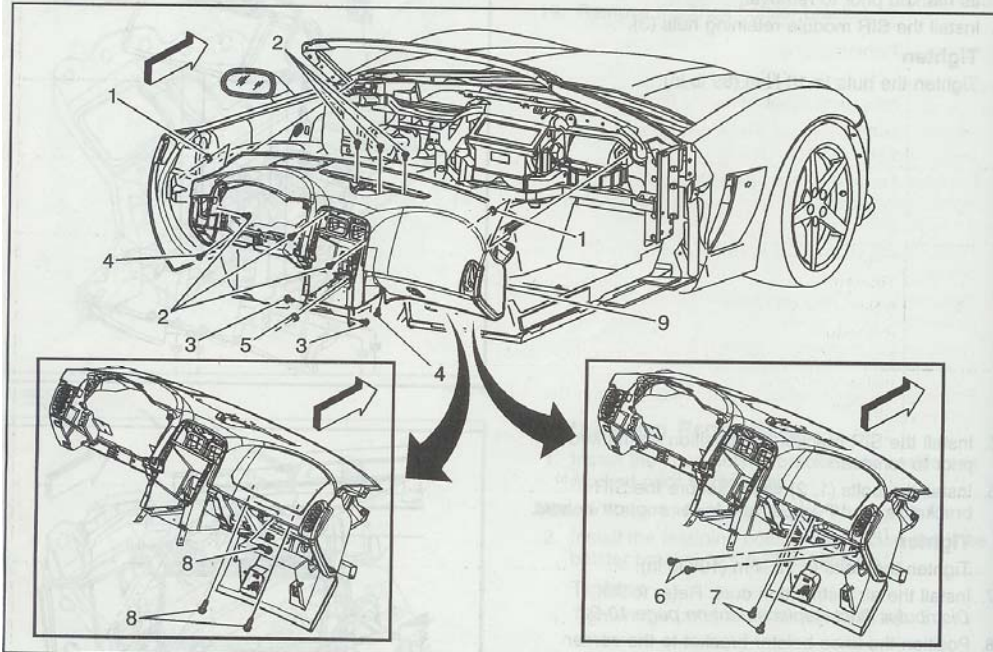

1406221

Instrument Panel Assembly Replacement

Callout	Component Name
Preliminary Procedures	
<ol style="list-style-type: none"> 1. Disable the SIR system. Refer to <i>SIR Disabling and Enabling</i> on page 13-120. 2. Remove the defroster grille. Refer to <i>Defroster Grille Replacement</i> on page 10-115. 3. Remove the steering wheel. Refer to <i>Steering Wheel Replacement</i> on page 15-71. 4. Remove the instrument panel cluster. Refer to <i>Instrument Cluster Replacement</i> on page 8-194. 5. Remove the instrument panel accessory trim plate. Refer to <i>Instrument Panel Accessory Trim Plate Replacement</i> on page 2-31. 6. Remove the right console trim panel. Refer to <i>Front Floor Console Side Trim Panel Replacement - Right Side</i> on page 2-50. 7. Remove the radio assembly. Refer to <i>Radio Replacement</i> on page 8-71. 8. Remove the instrument panel insulators. Refer to <i>Instrument Panel Insulator Panel Replacement</i> on page 2-29. 9. Remove the instrument panel driver knee bolster assembly. Refer to <i>Driver Knee Bolster Panel Replacement</i> on page 2-30. 10. Remove the automatic transmission control. Refer to <i>Automatic Transmission Control Replacement</i> on page 17-153. 	
1	Instrument Panel Assembly Trim Cover Nut (Qty: 4) Notice: Refer to <i>Fastener Notice</i> on page 0-10. Tighten 6 N·m (53 lb in)
2	Instrument Panel Assembly Screw (Qty: 3) Tighten 2 N·m (17 lb in)

Instrument Panel Assembly Replacement (cont'd)

Callout	Component Name
3	Instrument Panel Assembly Bolt (Qty: 2) Tighten 12 N-m (106 lb in)
4	Instrument Panel Assembly Screw (Qty: 2) Tighten 6 N-m (53 lb in)
5	Instrument Panel Assembly Nut Tighten 6 N-m (53 lb in)
6	Instrument Panel Assembly Screw Tighten 6 N-m (53 lb in) Procedure Open the instrument panel compartment to access the screws.
7	Instrument Panel Assembly Screw (Qty: 2) Tighten 2 N-m (18 lb in) Procedure Open the instrument panel compartment to access the screws.
8	Instrument Panel Assembly to Inflatable Restraint Module Bolt (Qty: 3) Tighten 12 N-m (53 lb in)
9	Instrument Panel Assembly Procedures 1. Note the location and routing of the instrument panel wiring harness prior to removal of the instrument panel assembly in order to ensure proper reinstallation. 2. With the aid of an assistant, lift the instrument panel assembly up and off of the upper and lower tie bars and over the steering column. 3. Remove the instrument panel assembly from the vehicle. 4. When replacing the instrument panel assembly, transfer all necessary components.

Step 6: Installing the HUD

Here you can see one of the mounting studs the HUD will secure to with the 6mm nut.

In this picture you can see the other mounting stud and the notch for the screw clip mount of the HUD projector.

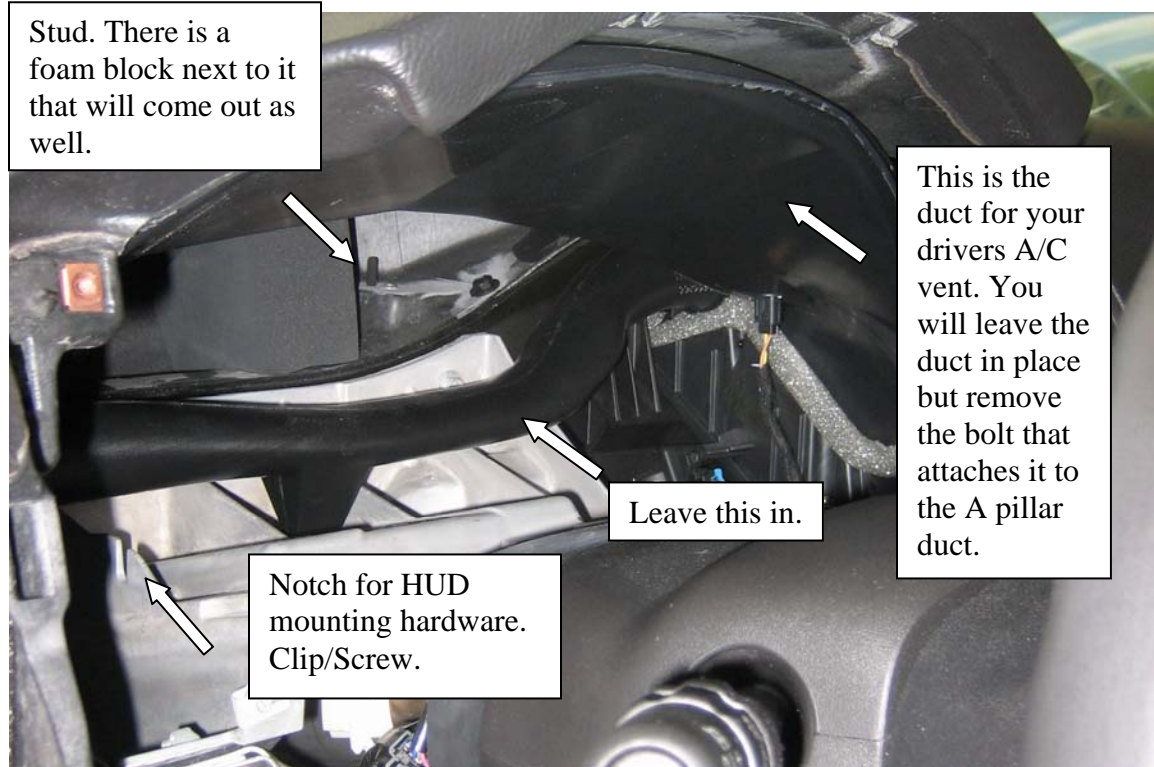

You will not have any trouble find the bolt connecting the A/C duct to the A pillar duct. Remove it and you will have enough slack to push the A/C duct upward enough to slide the HUD projector in place.



The other mounting stud is shown in the picture to the left.

This is the HUD projector. You can see the two tabs (left and barely the right) that will fit over the mounting studs. I secured them with 6mm locking nylon nuts. The front mount uses a clip with a horizontal screw. Mine came with the HUD projector but I'm sure if your's does not you can pick up a similar fastener at a local autoparts store or hardware store.



The electrical harness will plug in here on the side.

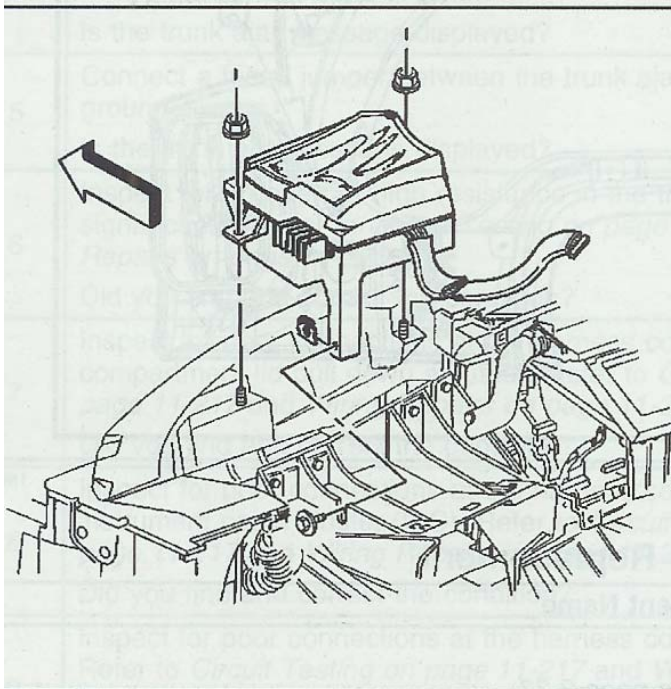

Installation Procedure

1. Transfer the retaining screw and nut to the replacement HUD.
2. Install the HUD to the vehicle:
 - 2.1. Install the HUD onto the dash panel mounting studs.
 - 2.2. Slide the HUD retaining screw into the slot on the steering column bracket.

Notice: Refer to *Fastener Notice* on page 0-10.

3. Install the HUD retaining nuts.

Tighten

Tighten the nuts to 5 N·m (44 lb in).

4. Tighten the screw that retains the HUD to the steering column bracket.

Tighten

Tighten the screw to 3 N·m (27 lb in).

5. Install the I/P assembly. Refer to *Instrument Panel Assembly Replacement* on page 2-44.
6. Connect the negative battery cable. Refer to *Battery Negative Cable Disconnection and Connection (6.0L)* on page 9-728 or *Battery Negative Cable Disconnection and Connection (7.0L)* on page 9-729.
7. Refer to *Control Module References* on page 6-3 for programming and setup information.

Once you have the HUD projector in place and secured with its hardware, you are ready to either take care of the wiring, or put the dash back together. It's really your call. If you are comfortable the HUD projector you received is in good working order, I would put

the dash back in the car. You will have ample room with the gauge cluster and steering wheel out of the way to do the wiring. I had no trouble doing it with the wheel in my way either.

The last thing you'll need to install before working on the wiring is the HUD controls. I know you can probably figure out how to mount it to the instrument panel, but here's a diagram anyway.

Repair Instructions

Head Up Display Switch Replacement

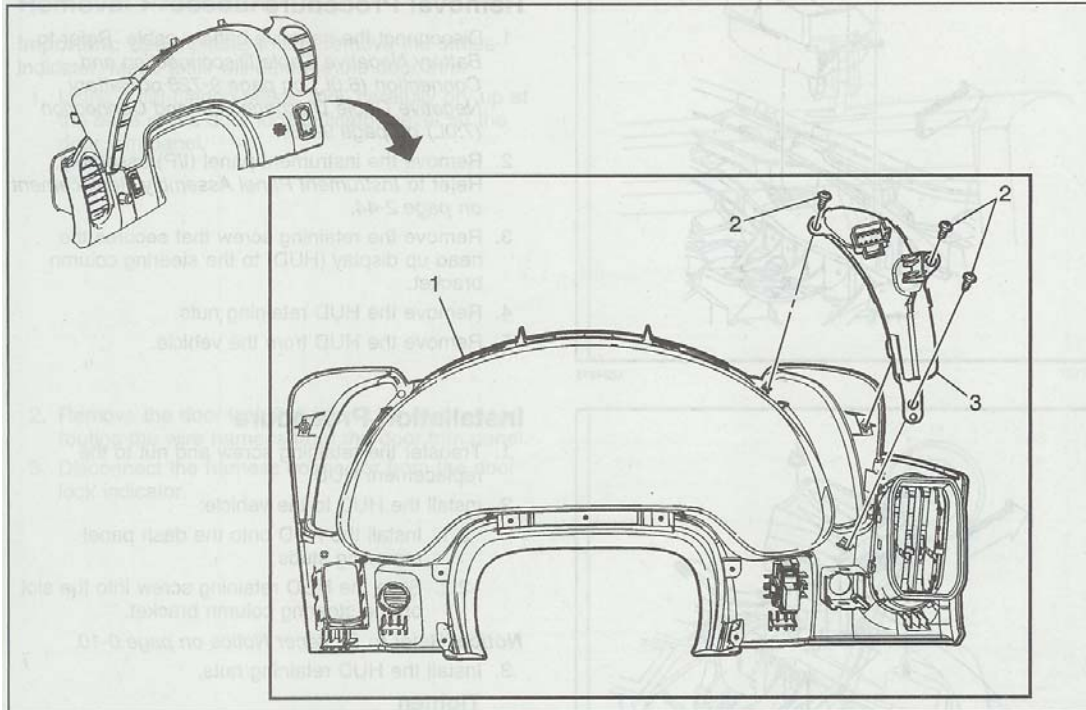

1803421

Head Up Display Switch Replacement

Callout	Component Name
1	Instrument Panel Cluster Trim Plate Refer to <i>Instrument Cluster Trim Panel Replacement</i> on page 2-33.
2	Heads Up Display Switch Screw (Qty: 3) Notice: Refer to <i>Fastener Notice</i> on page 0-10. Tighten 2 N-m (18 lb in)
3	Head Up Display Switch

HUD pictured in place. Now it's time to do the wiring.



Step 7: Wiring the custom HUD harness

This is the last step to the install. You will have a harness similar to below if you have purchased one off of the forum. Note that if you can get the plugs for the HUD control switch and projector with some short wire leads you could make your own harness.

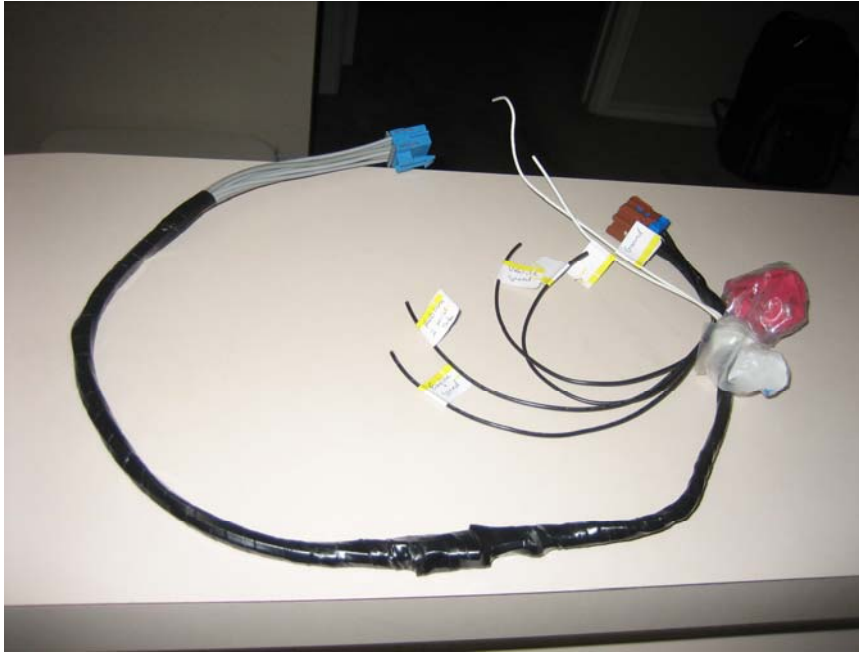

It's a pretty simple harness. The blue connector goes to the HUD control switch, the brown to the HUD projector, and the loose wires use the red t-taps (in the bag) to tap into the existing black and grey plug harnesses that go into the back of your gauge cluster.

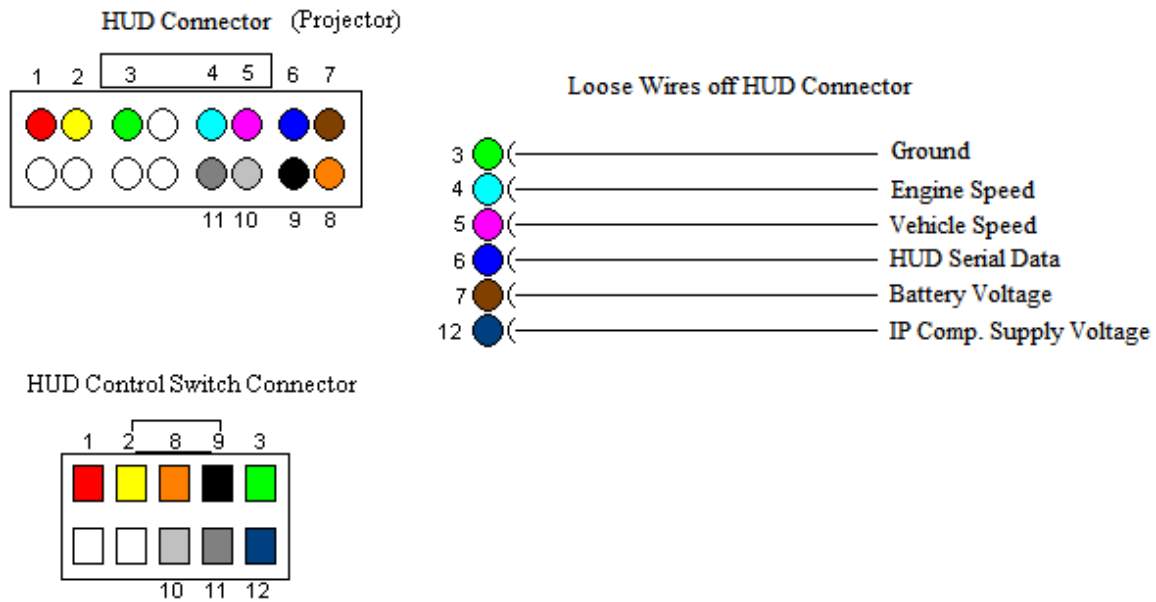

Note that the pins/descriptions marked in red are the ones that are brought out to loose wires off of the custom harness. These will be used for tapping into the instrument panel (aka gauge cluster) wiring. Those pins will also be marked in red and you will only need to match up the descriptions to figure out which loose wire (from the custom harness) taps into which colored wire (from your factory gauge cluster harness).

(To avoid confusion I just want to say that when I say “harness” it could mean the grey connector group of wires or the black connector group of wires. I know full well they are part of the same harness and they “Y” out into the two different connectors but it’s easier just to call each one a harness.)

You will want to make the connection with the t-taps as far back on the factory harness as possible. I did mine about 4 to 6 inches away from where the black and grey harnesses of the gauge cluster merge into one harness. I did this in part because the loose wires on the custom harness were quite short as you can see from the picture.

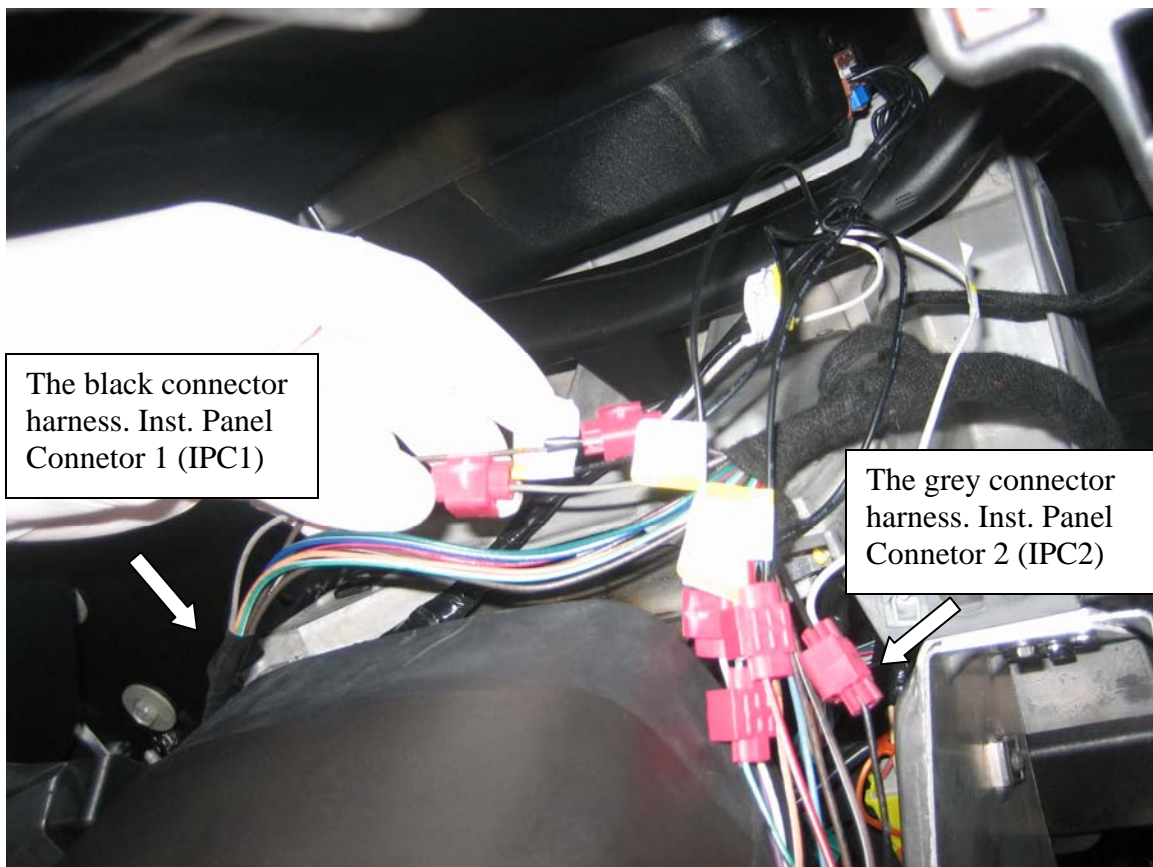

Another important note is that the factory harness is wrapped with this awful adhesive tape. It’s extremely sticky so you may want to use some gloves while removing it to access the underlying wires. You only need to take off about 4 to 6 inches of the wrap on each of the factory harnesses to use the t-taps. This approach will work for the black connector harness but not for the grey. Use a razor blade to cut the wrap but be very careful not to cut into the insulation of the underlying wires. Unwrap a few inches on the

black harness and leave the remaining wrap in tack. On the grey harness, you will most likely need to unwrap all the way down to the connector. The reason for this is you have to tap into a gray wire and there is more than one gray wire in this harness. All other wire colors are unique. You'll see that in my photo I unwrapped both completely. I used electrical tape after I was done making the taps. Make sure the taps are making contact with both wires before buttoning everything up. (I used a multimeter to check.)

When you are done, put the gauge cluster back in place and connect the black and grey connectors. Make sure you have the HUD control switch connector and DIC control switch connector routed on the sides so you'll be able to connect them to the switches on the instrument panel trim.

HUD Connector (Brown End of the Custom Harness)

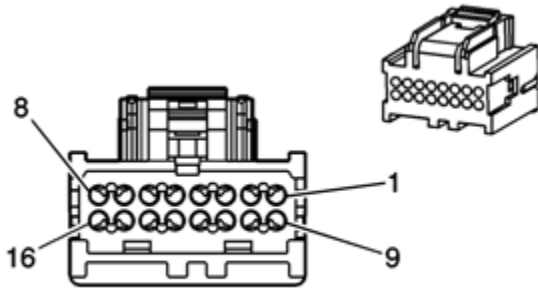

Pin	Function
1	Battery Positive Voltage
2	HUD Class 2 Serial Data
3	Vehicle Speed Signal
4	Engine Speed Signal
5	Not Used
6	Ground
7	HUD Image Up Signal
8	HUD Image Down Signal
9	HUD Page Signal
10	HUD Data Signal
11	HUD Dimming Up Signal
12	HUD Dimming Down Signal
13-16	Not Used

HUD Control Switch (Blue End of the Custom Harness)

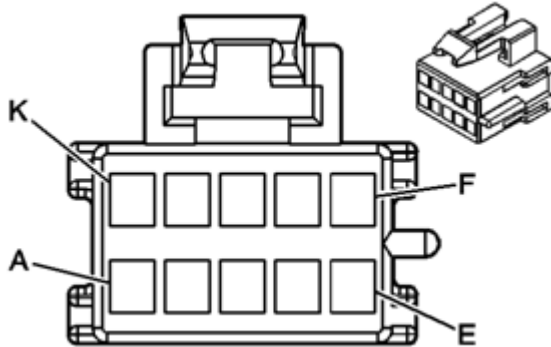

Pin	Function
A-B	Not Used
C	HUD Dimming Up Signal
D	HUD Dimming Down Signal
E	Instrument Panel Lamp Supply Voltage - 2
F	Ground
G	HUD Data Signal
H	HUD Page Signal
J	HUD Image Up Signal
K	HUD Image Down Signal

Instrument Panel Connector 1 (Black)

This is the black connector for the back of the gauge cluster. You take the loose wires from your custom harness and tap into pins 2 and 5 with the t-tap connectors.

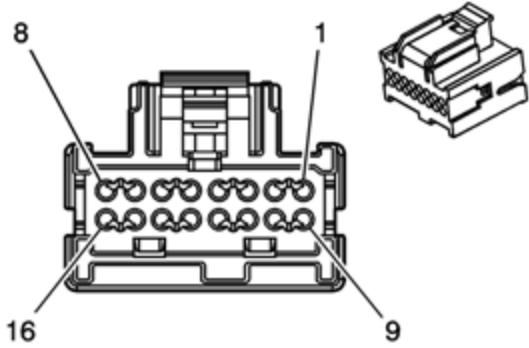

Pin	Wire Color	Function
1	BN/WH	Instrument Panel Lamp Dimming Control
2	BN	Instrument Panel Lamp Supply Voltage - 2
3-4	--	Not Used
5	GY	IPC Class 2 Serial Data
6	--	Not Used
7	TN	Low Reference
8	--	Not Used
9	BN	Hazard Flasher Signal
10-11	--	Not Used
12	D-BU/WH	Instrument Panel Lamps Dimmer Switch Down Signal
13	D-GN	Instrument Panel Lamps Dimmer Switch Up Signal
14	PK/BK	Dome Lamp Switch Signal
15	--	Not Used
16	D-GN/WH	Oil Temperature Sensor Signal

Instrument Panel Connector 2 (Grey)

This is the grey connector for the back of the gauge cluster. You take the loose wires from your custom harness and tap into pins 1, 3, 5, and 6 with the t-tap connectors.

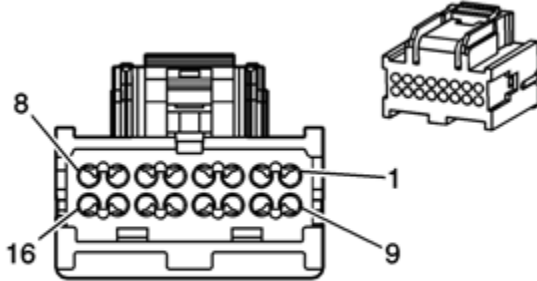

Pin	Wire Color	Circuit No.	Function
1	BK	1450	Ground
2	--	--	Not Used
3	RD/WH	1140	Battery Positive Voltage
4	--	--	Not Used
5	WH	121	Engine Speed Signal
6	D-GN/WH	817	Vehicle Speed Signal
7	BN	9	Park Lamp Supply Voltage
8	TN/WH	99	Windshield Washer Fluid Level Sensor Signal
9-13	--	--	Not Used
14	BN/WH	419	MIL Control
15	L-BU	1134	Park Brake Switch Signal
16	PU	333	Brake Fluid Level Sensor Signal

Final Steps / Reflections

After you are done cleaning up the harness you will most likely want to rush and get everything back installed so you can try it out. I'd recommend taking your time or you will most likely forget to reconnect something. The good news is, even if you made a wiring mistake, taking the instrument panel and gauge cluster out to access the wires is a relatively simple task.

I will not be outlining the steps to reinstall the dash, steering wheel or console. I have no doubt that if you took it apart, you will be able to put it back together. The last piece left to install is the HUD bezel.

2-32 Instrument Panel and Console Trim

Instrument Cluster Head Up Display Bezel Replacement

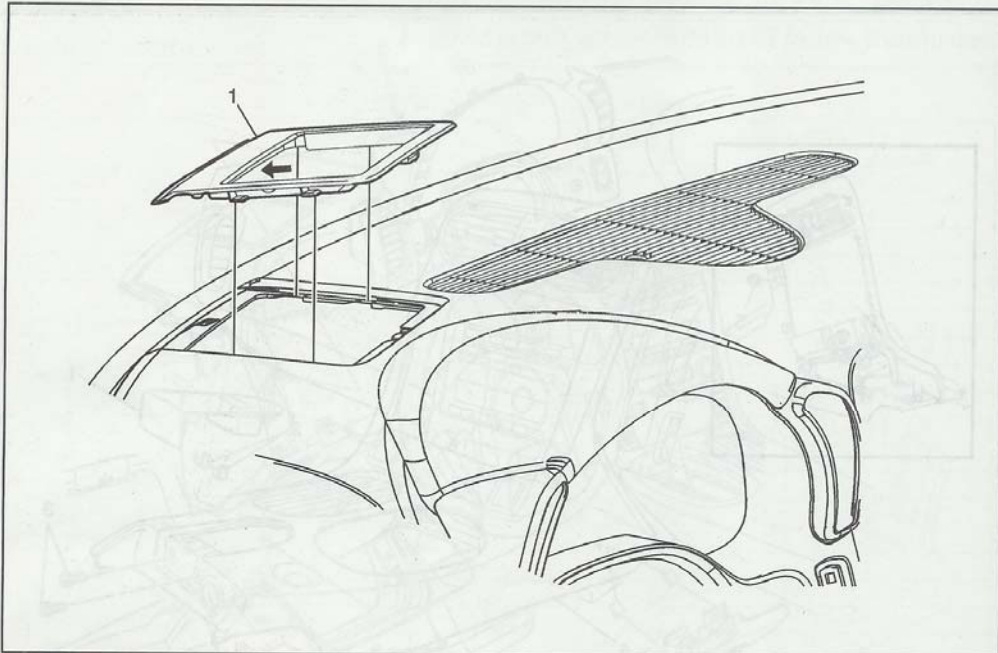

1866000

Instrument Cluster Head Up Display Bezel Replacement

Callout	Component Name
1	<p>Instrument Cluster Head Up Display Bezel</p> <p>Notice: Use care to avoid damage to the head up display (HUD) lens when removing and installing the HUD bezel. The HUD lens is fragile. Failure to carefully remove/install the bezel can lead to HUD lens damage.</p> <p>Procedure</p> <ol style="list-style-type: none">1. Insert a flat bladed plastic trim tool in the middle of the forward edge of the bezel where indicated.2. Slide the bezel forward disengaging the retainer tabs securing the bezel to the Instrument panel trim pad.

Hopefully you are done now with your installation and everything is working like it should. If you have any questions that I may be able to help with please feel free to contact me at damianforeman@gmail.com

For those interested on what I broke/damaged because of leaving my steering wheel in:

- Lower plastic crossbrace of dash that goes under the steering column was broken at the radio surround area. (see pic)
- A couple of cracks in the radio surround area of the plastic (this was not intentional however it happened anyway.)
- Nicks and scratches on the steering wheel rim. This is kinda a given with all the sharp plastic of the dash.

Now for me, my car is a daily driver and a hobby so these things don't bother me. The steering wheel will eventually be getting replaced with something a little nicer. The other damage was repaired and is not visible.

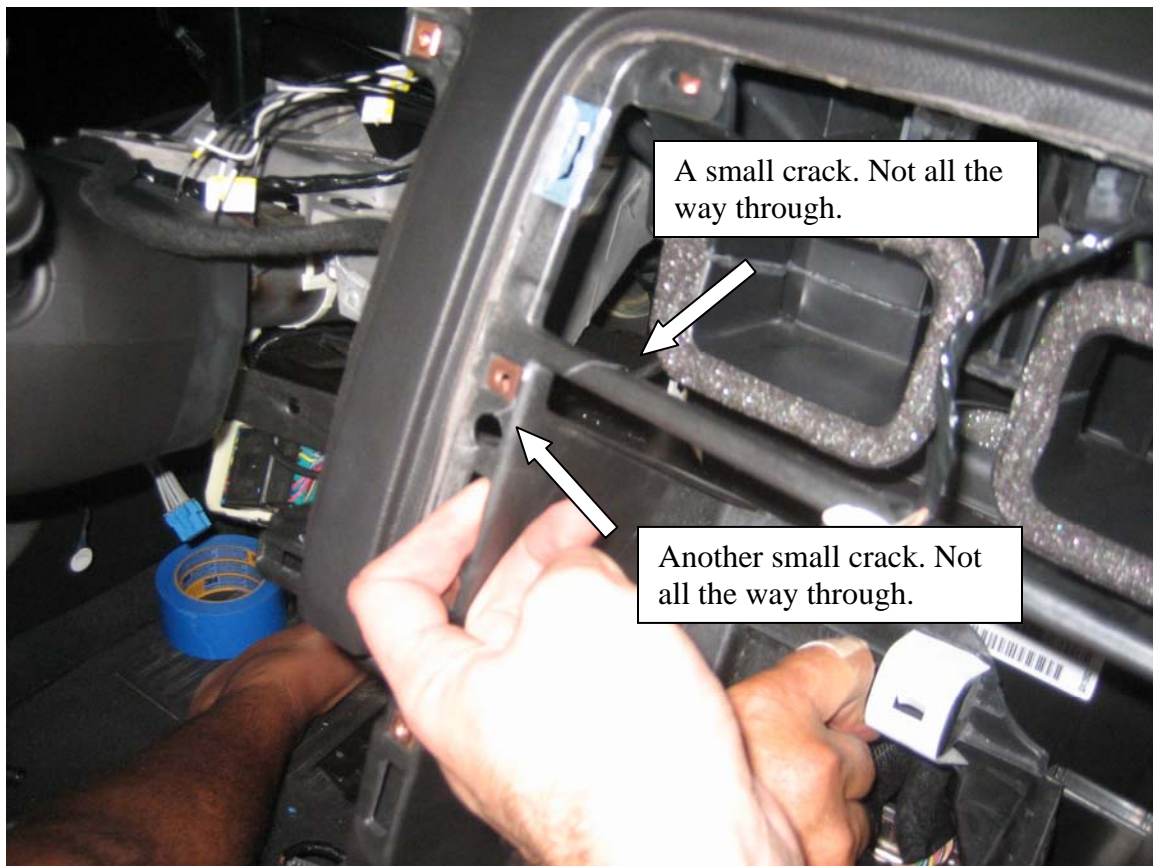

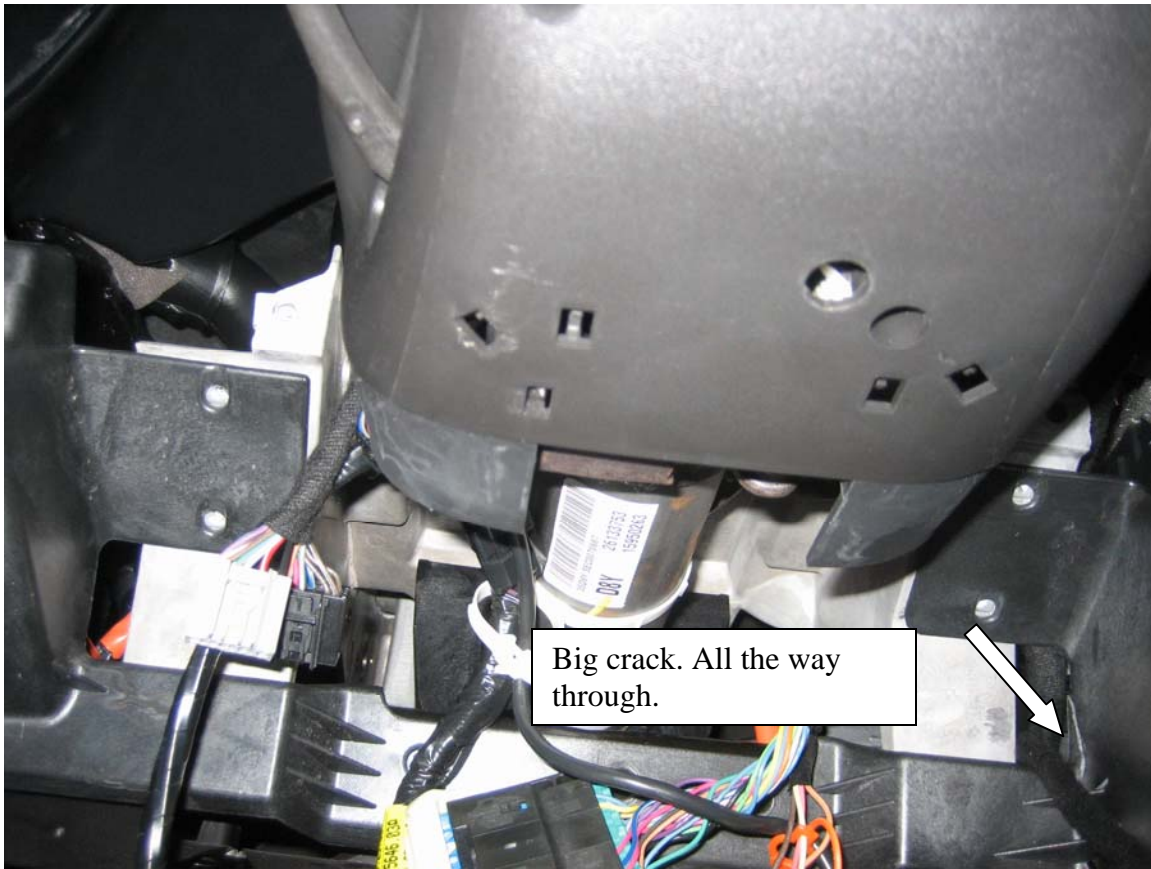

I couldn't get a great picture of the steering wheel scratches. You can see it slightly in the picture below.



But in the end, was it worth it? Absolutely. And the HUD works just fine on the regular glass in bright daylight.

